

# WORXSAFE

Part of Ramudden Global

WORK ZONE SAFETY. DELIVERED

# TORUN<sup>®</sup>

The New Generation of City Barriers

Tested according to EN 1317-2 in capacity class T1, T2, T3 and N1

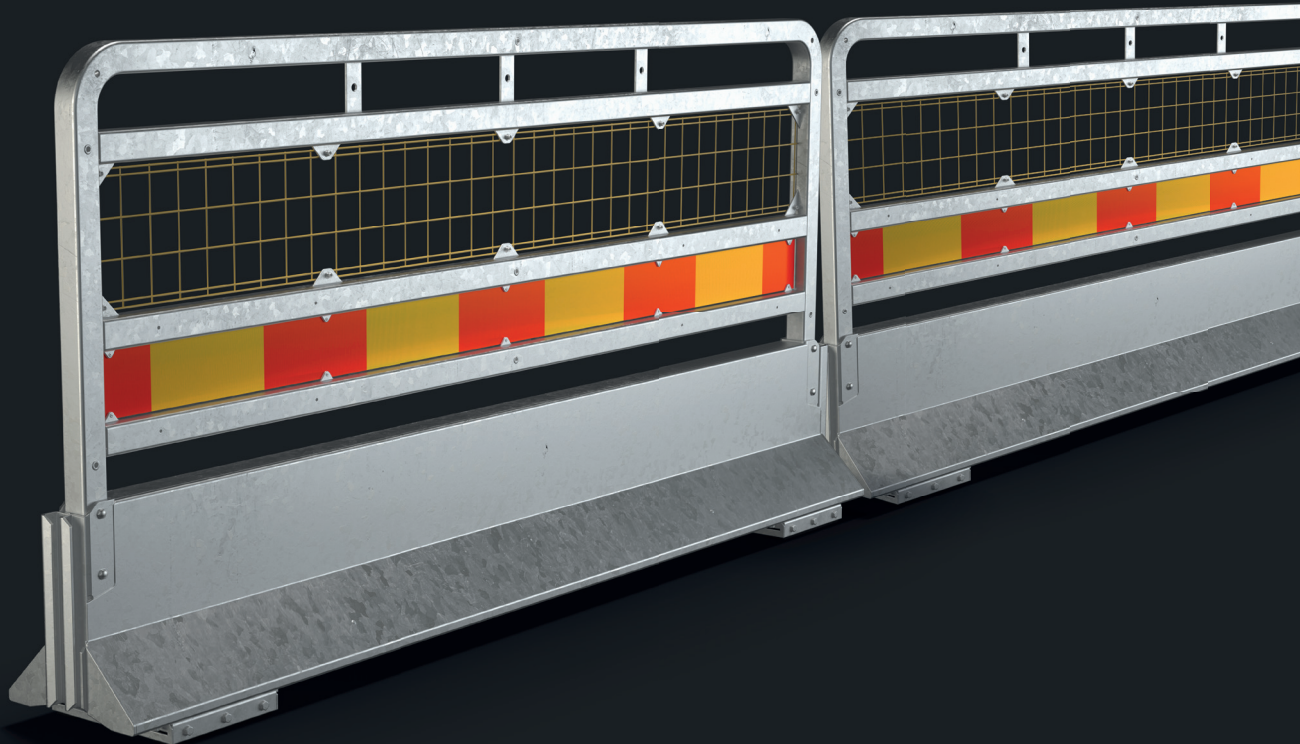

Rev 2419

# List of content

**1****Torun Barriers Sections****4**

---

Barrier 2.85 m	6
Barrier 1.425 m	8
Barrier Installation	10
Lifting	13
Storage and Maintainance	14
Performance Data	17

# Torun city barriers redefining urban protection

Are you ready to revolutionize city safety and infrastructure maintenance? Meet Torun, the cutting-edge city barrier system designed to exceed all expectations. Torun offers unparalleled performance and versatility, making it the ultimate solution for urban environments.

## One-step installation without ground anchoring

One of Torun's most impressive features is its ability to link barriers seamlessly without any human touch or extra parts. This innovative design ensures quick and hassle-free installation, saving both time and resources. Say goodbye to cumbersome anchoring requirements, Torun's free-standing structure provides stability and security without compromising performance.

## Redefining safety standards through unmatched crash-tested performance

Safety is paramount, which is why Torun is crash-tested according to EN 1317-2 standards in capacity classes T1, T2, T3, N1 with astonishing results. Trust Torun to withstand the toughest conditions and protect both workers and the public.

## Seamless protection

But Torun doesn't stop there. Its adaptable design allows it to follow the ground seamlessly, accommodating height differences and uneven terrain effortlessly. Whether you're navigating busy city streets or uneven landscapes, Torun ensures consistent protection and peace of mind.

## SS 7750-1 for pedestrian and bicyclist safety

The Torun System is designed and tested according to the regulations in EN-1317 and the newly released Swedish standards SS 7750-1, covering pedestrian safety for temporary fencing and barriers. It is meticulously crafted and tested to ensure compliance with regulations, specifically addressing pedestrian and bicyclist safety.

## Components for added functionality

But that's not all—Torun comes equipped with multiple extra components for added functionality. Need to display signs, attach nets, or enhance visibility with reflectors? Torun has you covered. With its versatile design and customizable options, Torun adapts to your specific needs with ease.

## If needed you can replace all parts

Torun is flexible where it matters. You can choose reflectors that suit your region. If the barrier get damaged, you can replace all parts, such as the barrier railing.

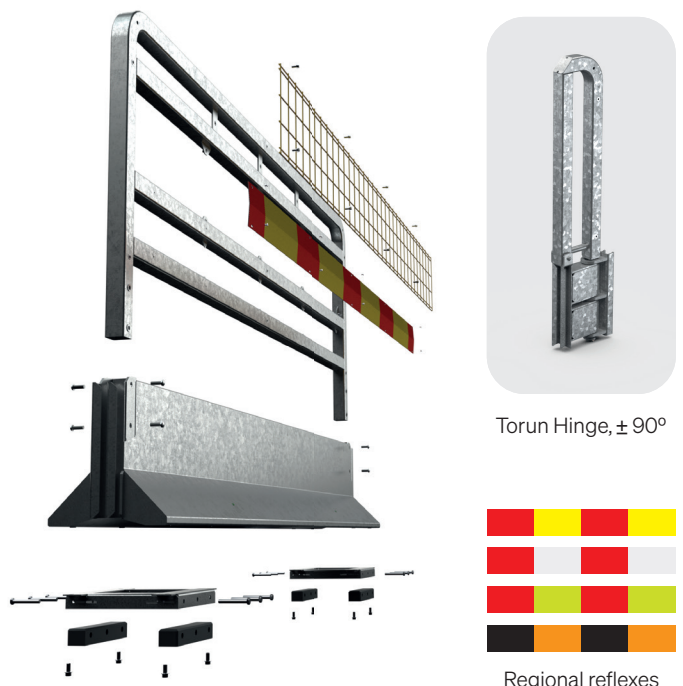

Torun Hinge,  $\pm 90^\circ$

Regional reflexes



# 1 TORUN Barrier Sections

**Two length options allowing for customization in any project**

- All barrier sections have the same simple connection for fast installation and removal.
- Torun comes in two distinct lengths for varied application needs.
- Barrier performance validated through EN 1317 testing.
- Each barrier is equipped with a galvanized steel frame prolong its lifespan.
- All steel components are hot-dip galvanized in compliance with ISO 1461, ensuring optimal durability.

## ■ Componets - Torun Barrier Sections

---

### 8346000 - Torun 2.85 m

Highly versatile and particularly favored in urban environments, where short setups are essential.

Minimum installed length:

**T1:** 57.2 m **T2:** 37.2 m **T3:** 57.2 m **N1:** 57.2 m

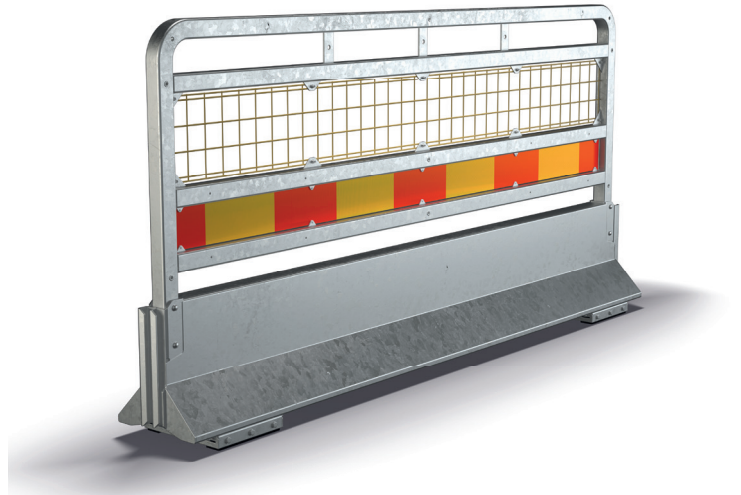

### 8345990 - Torun 1.45 m

The small Torun barrier, ideal for situations where space is limited.

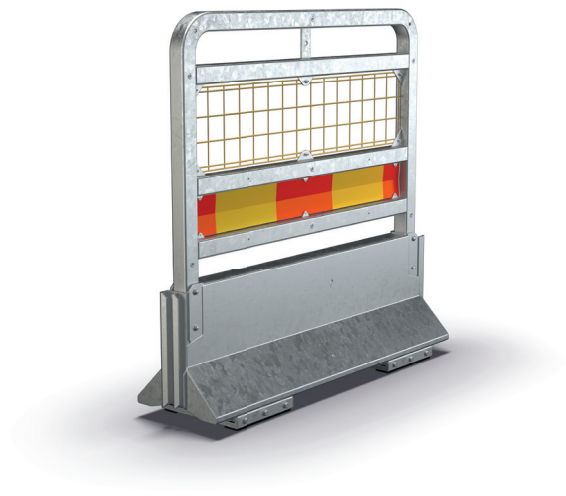

### 8346273 - Barrier Hinge

Allows for a turning radius of up to 90° in both directions, perfect for navigating through challenging urban landscapes.





# 8346000 - Torun Barrier 2.85

Torun redefines urban safety with its outstanding performance and remarkably low weight. Crafted with precision, it offers robust protection while seamlessly blending into city landscapes. Torun sets the standard for modern urban security.

## Compliance:

- EN 1317-2 T1/T2/T3/N1



### Dimensions

Length: 2850 mm  
Height: 1400 mm  
Depth: 380 mm



### Weight

570 kg



### Material

Concrete,  
Steel &  
Rubber



### Turning radius

25 m

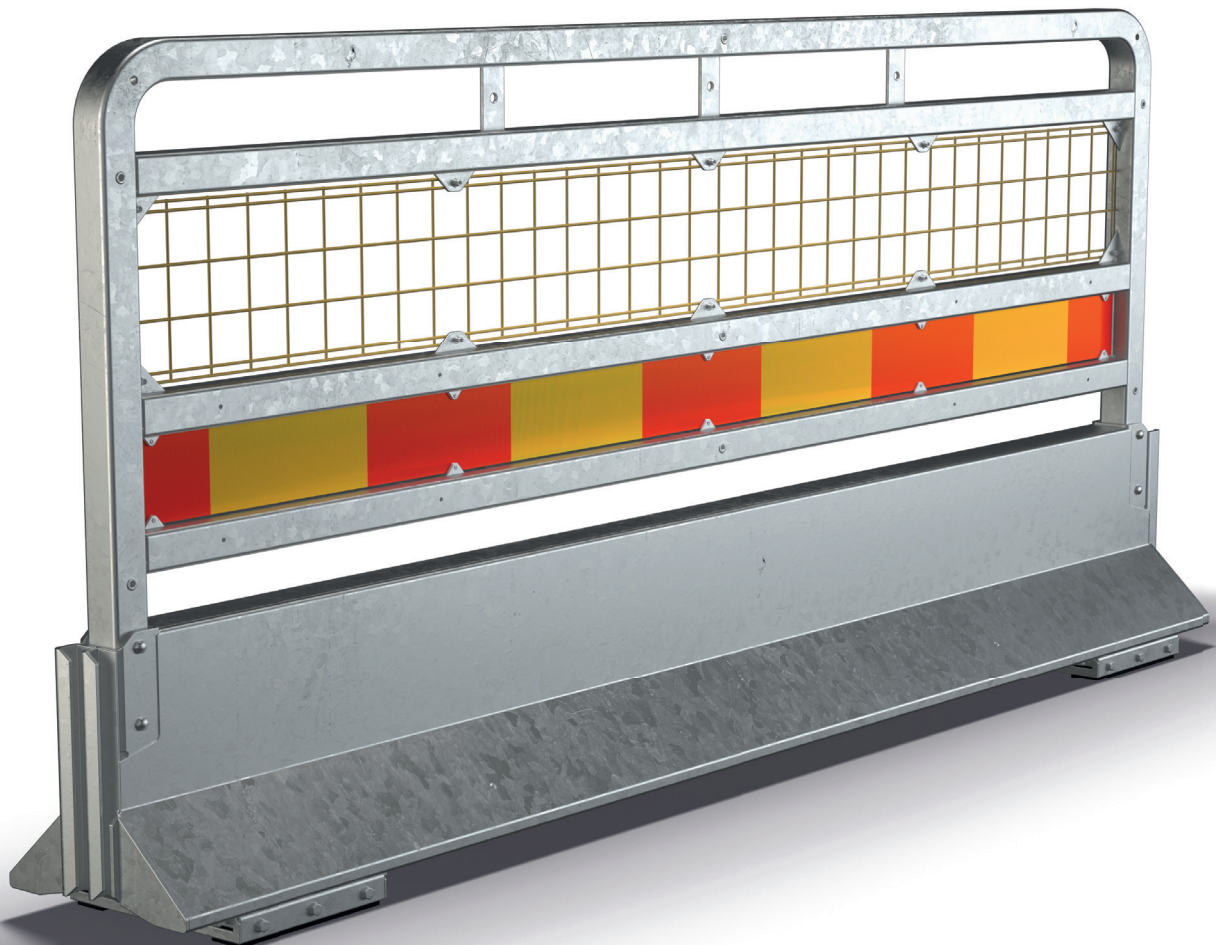

## T1 - Low angle containment

Containment    Min. installed length    Min. Amount    Working width    Impact severity    Installation time

**T1            57.2 m            20 pcs            W1            A            25 min**

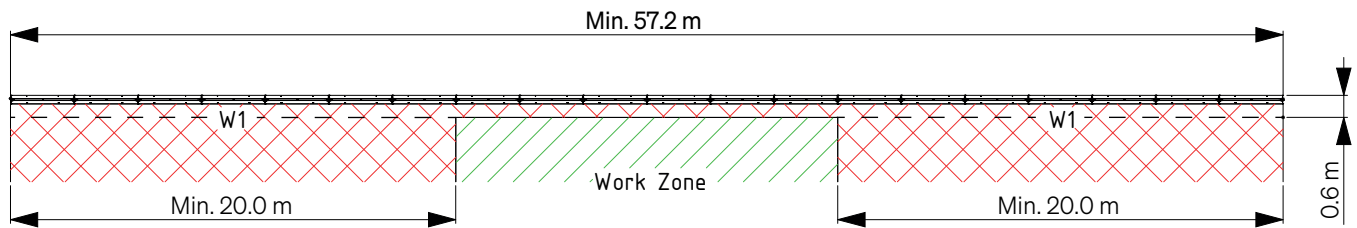

## T2 - Low angle containment

Containment    Min. installed length    Min. Amount    Working width    Impact severity    Installation time

**T2            37.2 m            13 pcs            W3            A            15 min**

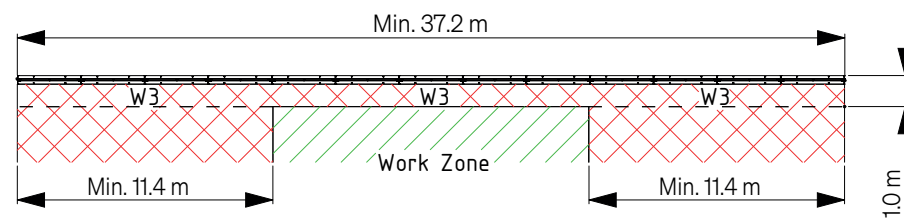

## T3 - Low angle containment

Containment    Min. installed length    Min. Amount    Working width    Impact severity    Installation time

**T3            57.2 m            20 pcs            W3            A            25 min**

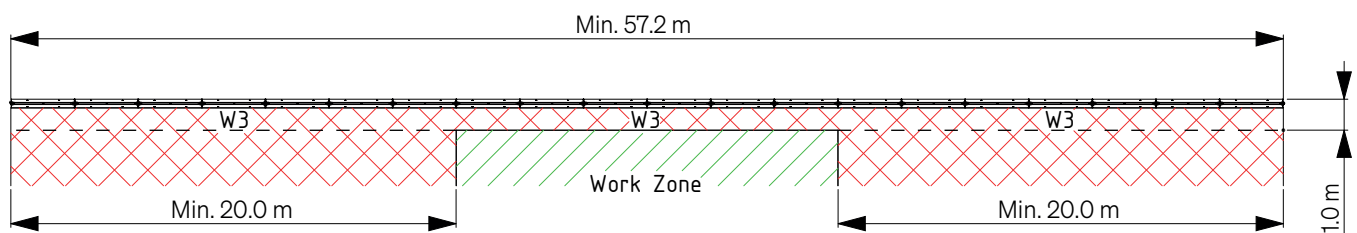

## N1 - Normal containment

Containment    Min. installed length    Min. Amount    Working width    Impact severity    Installation time

**N1            57.2 m            20 pcs            W5            A            25 min**

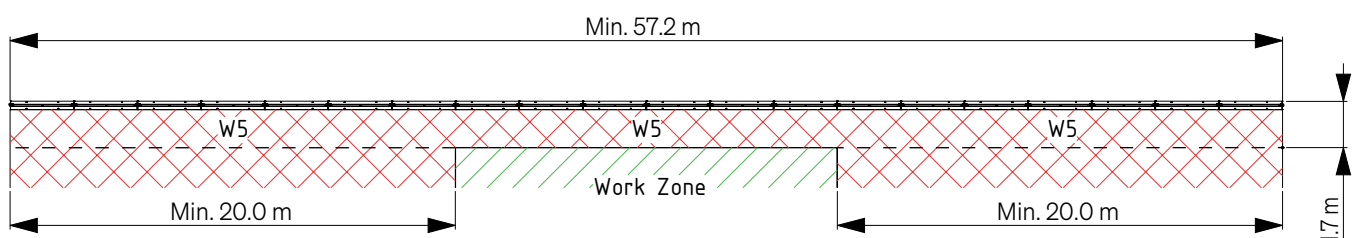

# 8345990 - Torun Barrier 1.45

Torun redefines urban safety with its outstanding performance and remarkably low weight. Crafted with precision, it offers robust protection while seamlessly blending into city landscapes. Torun sets the standard for modern urban security.



## Dimensions

Length: 1450 mm  
Height: 1400 mm  
Depth: 380 mm



## Weight

305 kg



## Material

Concrete,  
Steel &  
Rubber



## Turning radius

12.5 m







# Barrier Installation

With Torun, connecting barriers is quick and effortless – no need to be right beside them. Just one smooth motion and they're securely linked, no screws or additional joints required. Plus, with the unique design, you can easily disengage a barrier mid-setup without any hassle or disruption.

- No need to stand close to the barriers when installing.
- Dissengage any barrier in the middle of a setup without hassle or disruptions.
- No need for screws or tools

## Installation checklist

- Conduct a risk assesment before assembly.
- Inspect the barriers prior to every use to be sure that they are not damaged and that the rubber feet are in good condition. (For a full inspection protocol, see page 15).
- Make sure that all barriers are connected.
- Make sure that the surface behind the barrier is free from foreign objects, standing water, ice and snow.

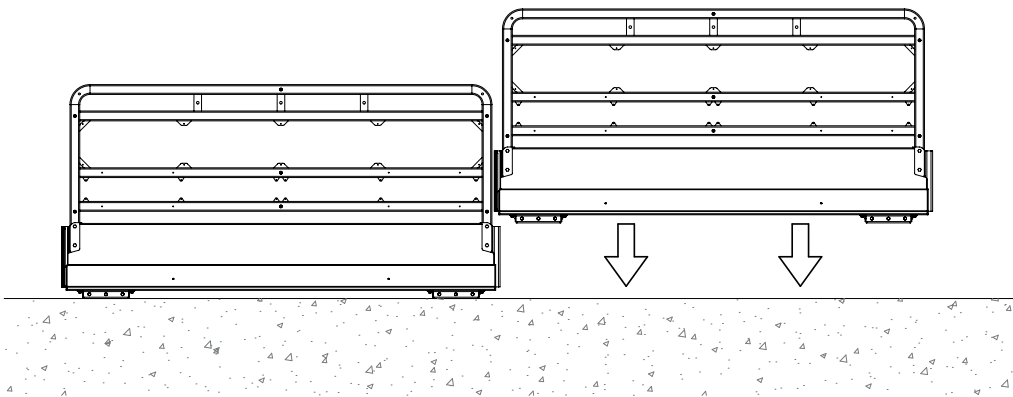

**Make sure that all barriers are connected.**

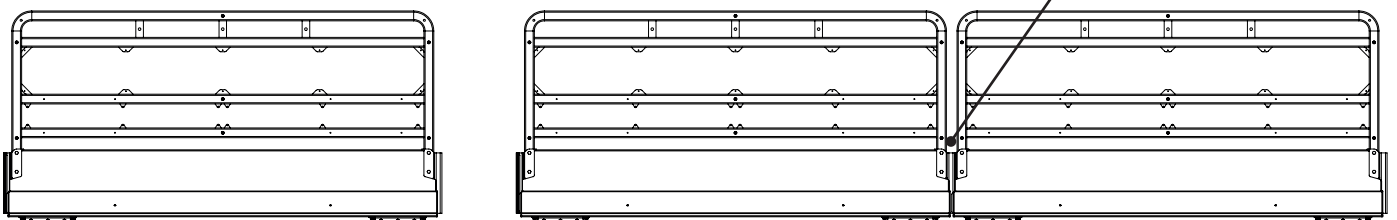
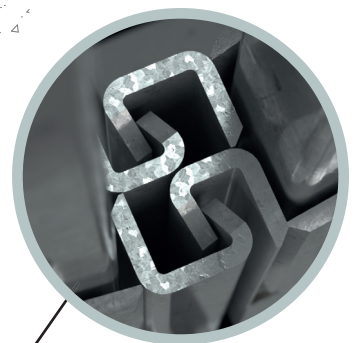

## Installation

### Remove any barrier in the middle of a setup

The coupling of Torun is easy and quick to use and with no need for screws or tools the Torun barrier can easily be disengaged or engaged in the middle of a setup. This is extra effective in emergency situations where barriers need to be cleared to create a clear path for emergency vehicles.

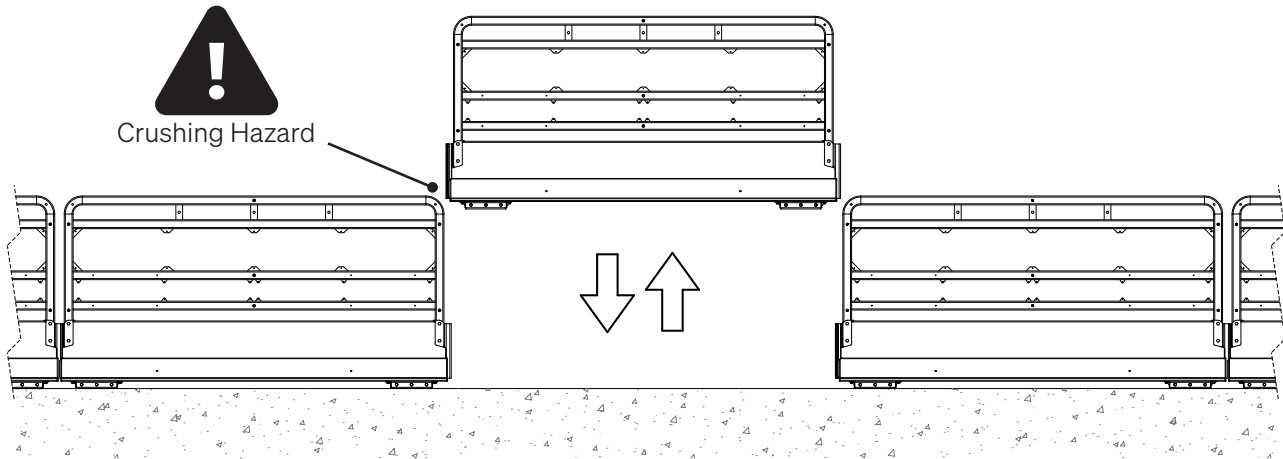

### Height difference

The Torun Barrier is flexible and able to climb edges like sidewalks and other uneven surfaces without losing the engagement of the coupling. The coupling can take approximately 250 mm height difference.

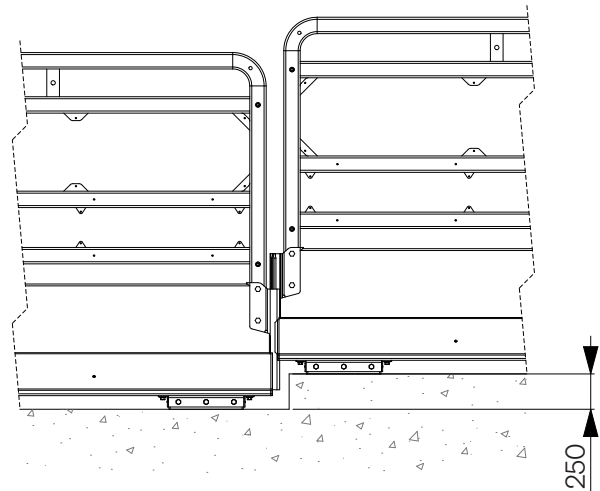

### Ground angle

The Torun coupling can take up to 1.8° change of angle, meaning it can scale light slopes without the need to disengage the coupling.

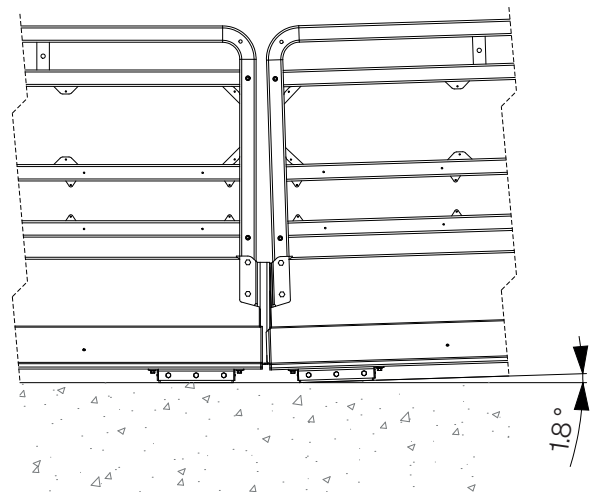

## Installation

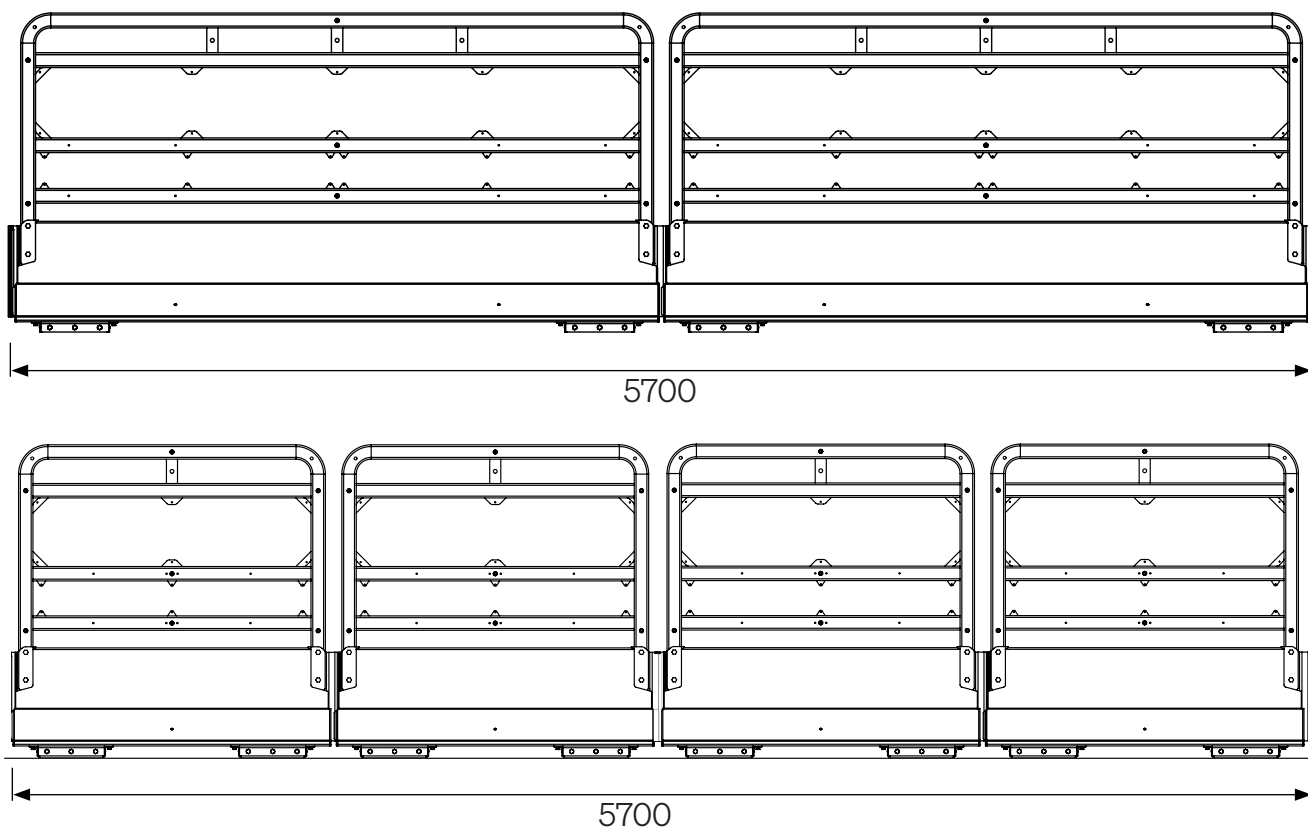

## Turn radius

The Torun barrier is ideal for urban tasks due to its low radius, enabling swift maneuverability in tight spaces. Its agility makes it perfect for navigating city streets efficiently, facilitating various urban operations.

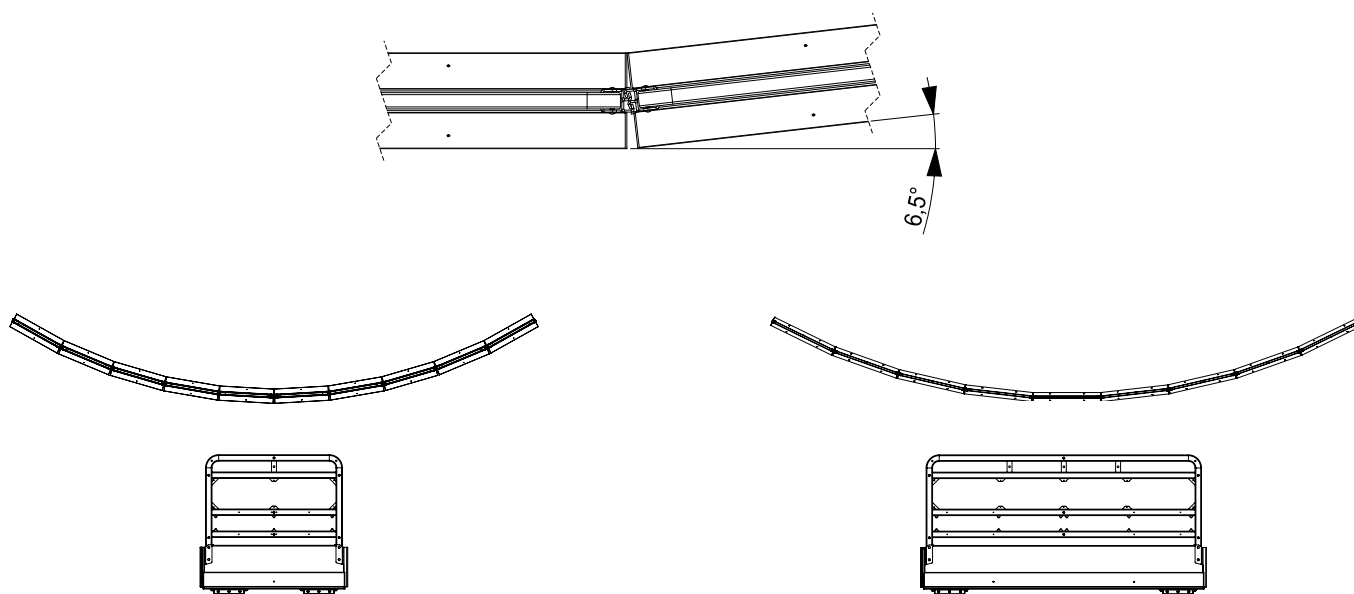

Torun 1.45 m: Turn radius 12.5 m

Torun 2.85 m: Turn radius 25 m

# Lifting

## To think about before lifting

- Use only designated lifting tools.
- Exercise caution regarding the risk of crushing.
- Ensure the barrier is not stuck, frozen to the ground or blocked in any way to avoid overloading the lifting equipment.
- Never lift multiple connected barriers.
- If using lifting forks, ensure that the forks and railing are free from snow and ice.
- Ensure that the necessary documentation for the chosen lifting equipment is available and that instructions are followed.

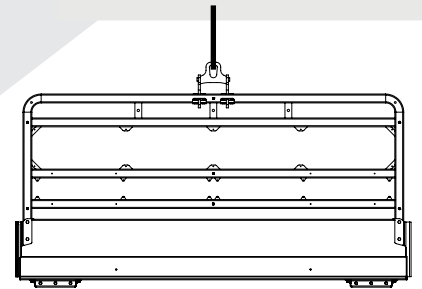

### Stand clear from moving barriers!

Never lift a barrier if a person is in its path of motion. Take caution to never lift a barrier above yourself or anyone else.

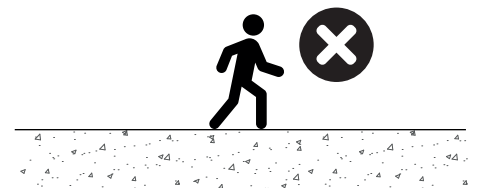

### Never lift more than one barrier!

Doing so can pose significant risks, including strains on couplings, lifting track and lifting tools.

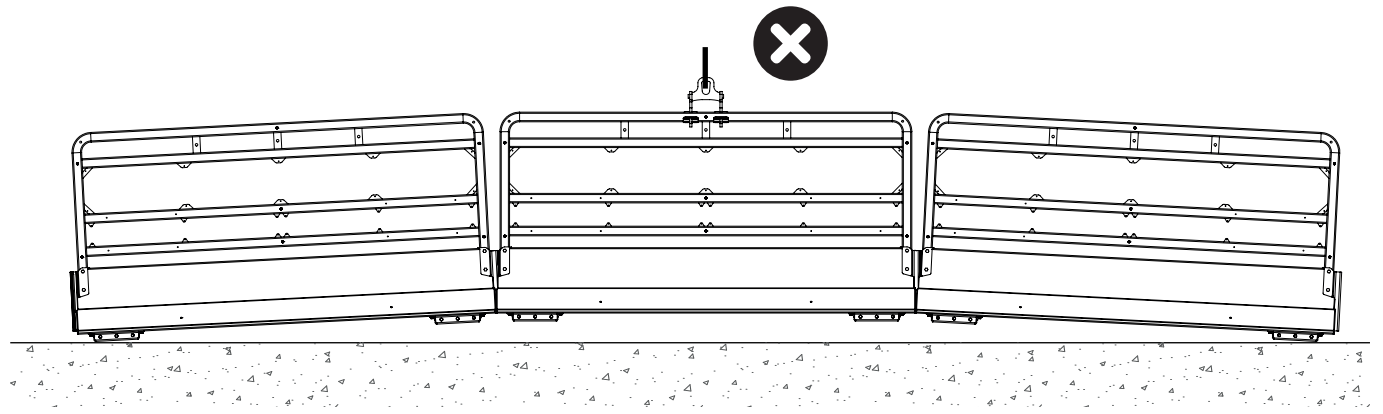

### Never drag barriers!

Dragging barriers will damage the barrier's rubber feet and put excessive strain on the lifting track and lifting tools.

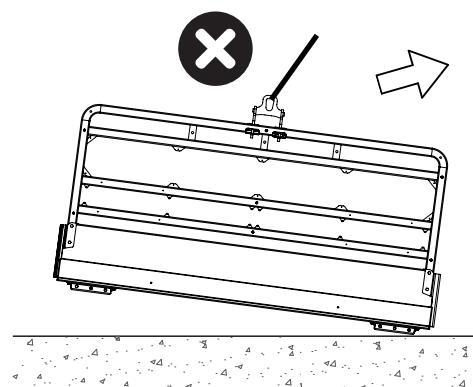



# Storage & maintenance

## When the barriers are in storage following safety precautions must be taken:

- To avoid compression of the rubber feet under prolonged heavy load, each stack must be separated by 100 mm. Place the separating blocks on the concrete surface and not on the rubber feet.
- A maximum of 2 barriers may be stacked in height.
- Ensure that the ground has sufficient bearing capacity and that the setup surface is as horizontal and smooth as possible.

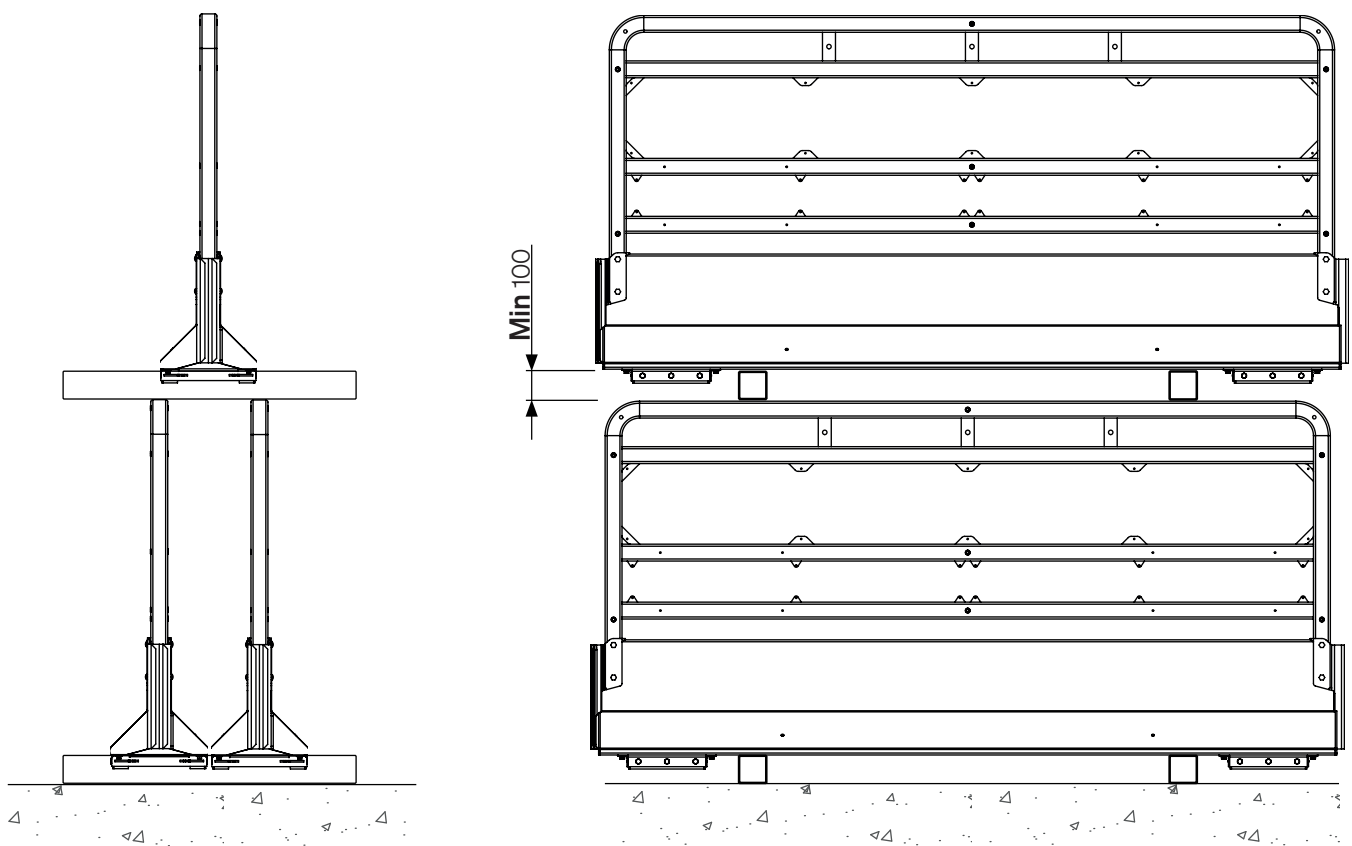

## ■ Inspection checklist

### Before each use, a simple check is recommended:

- Visual inspection of visible damage to the barrier components,
- Signs of impact or dropped barrier during lifting or similar.
- Inspection of wear on the rubber feet. Ensure that the rubber have at least 3 mm to the metal frame.
- Tighten any loose screws and make sure railing is correctly installed.

### Annually check the Torun barrier for the following:

- Cracks/rust in or around welds.
- Cracks or deformations around railing and screw sockets.
- Damage in between and around each horizontal beam.
- Wear on rubber feet. New feet have a thickness of 9 mm to the metal frame.  
Replace the foot when 3 mm remains

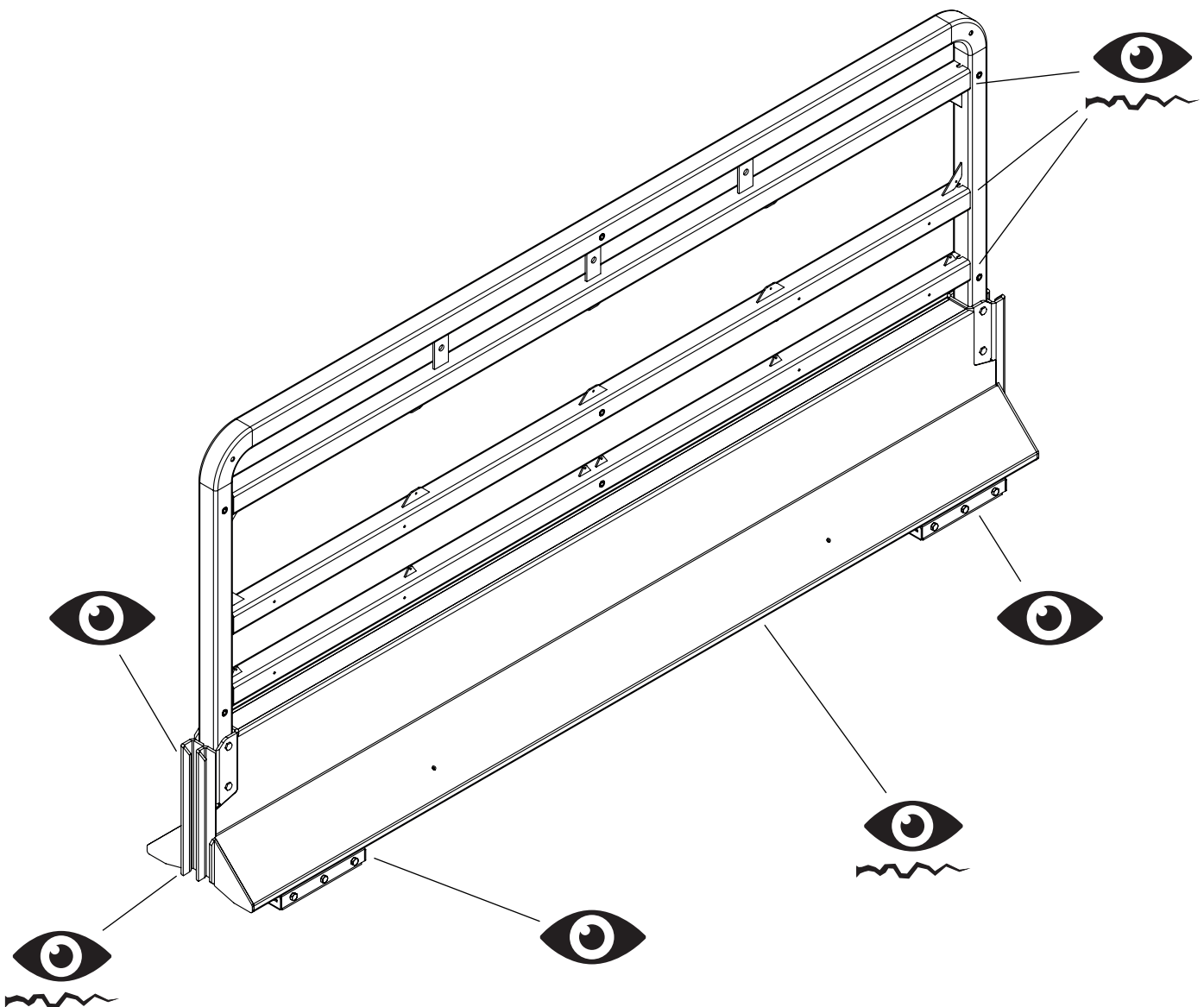

For assessment of damaged barriers, contact **Worxsafe AB**

## Railing Installation

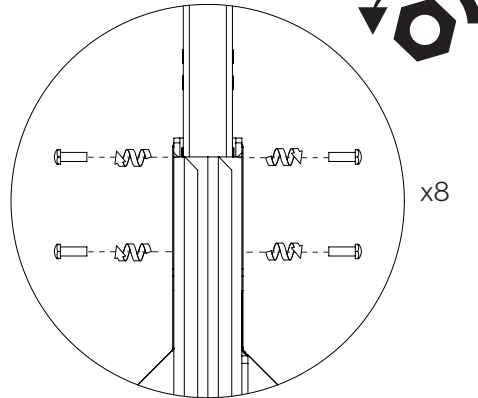
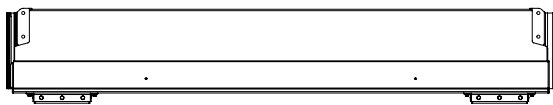
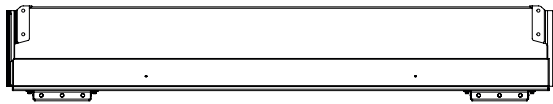
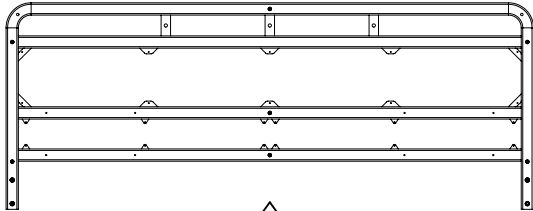

x8

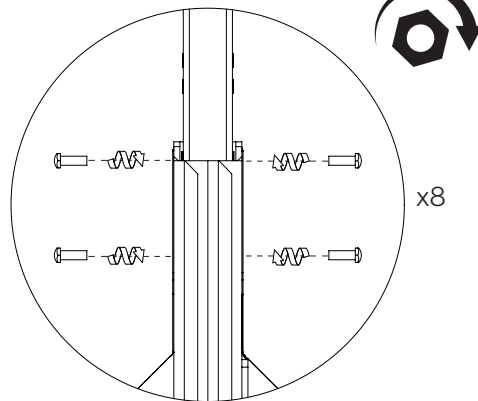

x8

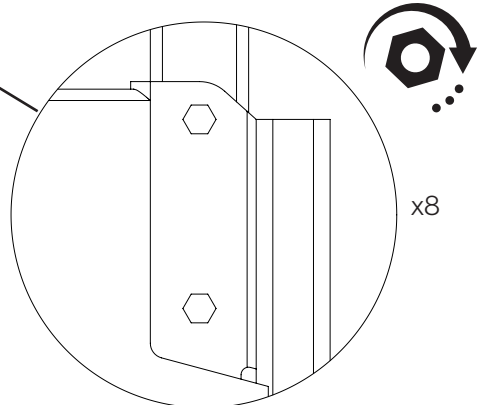

x8

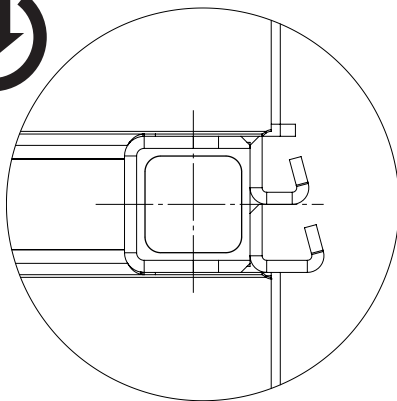

# Performance Data

## Torun 2.85 m

The performance figures relate to installation on an asphalt base in accordance with EN 1317-2.

### Low angle barrier installation

EN 1317-2 T1	
Barrier length	2.85 m
Barrier weight	570 kg
Min installation weight	11.400 kg
Min Barriers	20 pcs
Min installation length	57.2 m
Working width class/Working width dimension	W1 / 0.6 m
Min erected length before/after work zone	20 m
ASI (Acceleration Severity Index)	0.5
THIV (Theoretical Head Injury Velocity)	10 km/h
Injury risk class	A

### Low angle barrier installation

EN 1317-2 T2	
Barrier length	2.85 m
Barrier weight	1280 kg
Min installation weight	7.410 kg
Min Barriers	13 pcs
Min installation length	37.2 m
Working width class/Working width dimension	W3 / 1.0 m
Min erected length before/after work zone	11.4 m
ASI (Acceleration Severity Index)	0.7
THIV (Theoretical Head Injury Velocity)	13 km/h
Injury risk class	A

### Low angle barrier installation

EN 1317-2 T3	
Barrier length	2.85 m
Barrier weight	570 kg
Min installation weight	11.400 kg
Min Barriers	20 pcs
Min installation length	57.2 m
Working width class/Working width dimension	W3 / 1.0 m
Min erected length before/after work zone	20 m
ASI (Acceleration Severity Index)	0.5
THIV (Theoretical Head Injury Velocity)	10 km/h
Injury risk class	A

### Normal barrier installation

EN 1317-2 N1	
Barrier length	2.85 m
Barrier weight	570 kg
Min installation weight	11.400 kg
Min Barriers	20 pcs
Min installation length	57.2 m
Working width class/Working width dimension	W5 / 1.7 m
Min erected length before/after work zone	20 m
ASI (Acceleration Severity Index)	0.6
THIV (Theoretical Head Injury Velocity)	15 km/h
Injury risk class	A

**WORK ZONE  
SAFETY.  
DELIVERED.**

**WORXSAFE**

[www.worxsafe.com](http://www.worxsafe.com)