



CE Certified
Patented
Galvanised
Steel/Concrete



Licence decision of the Swedish
Transport Administration (Trafikverket)
in capacity classes T2 and T3

SVEA barrier system

SVEA WXS 2.85 is part of a product system for temporary use and is primarily intended as a continuous road restraint system.

The barrier has been crash-tested according to standard SS-EN 1317-2 in capacity classes T2, T3 and N2.

Great emphasis has been placed on fast and safe installation, short erected set lengths and elimination of any need to anchor the sections.

Dimensions

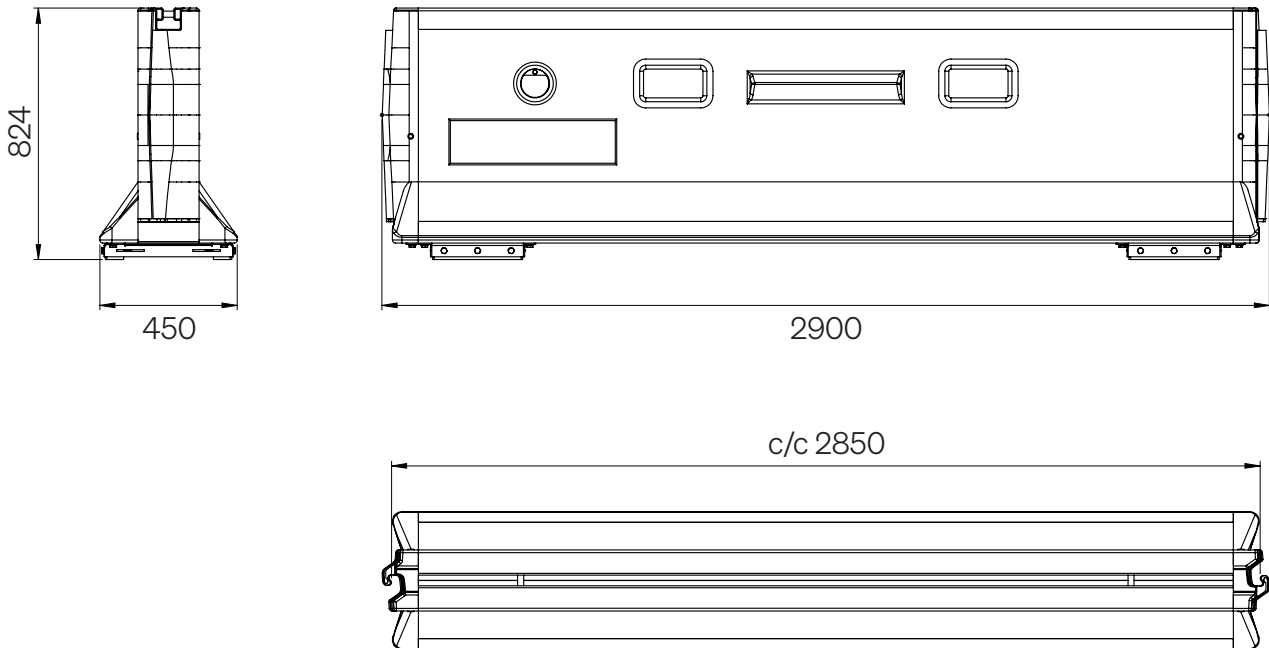

Installation instructions

No external locking devices are needed to connect the barriers together. The geometries of the end connectors are designed in the form of hooks which allow the sections to interlock.

The end connectors are chamfered, which allows the barriers to be positioned at an angle, as well as acting as a guide during installation. The barriers are lifted vertically into position using one of the methods described in the section “Safe lifting”.

Since both connecting ends of the barriers are symmetrical, the barriers can be erected in any direction. This also means that, if needed, a barrier section can be removed from the centre of an erected set of barriers, resulting in good flexibility.

The barriers are intended to be used entirely free-standing, without any need to anchor them in place.

Proper installation requires that all the relevant barrier sections must be connected together.

Installation instructions

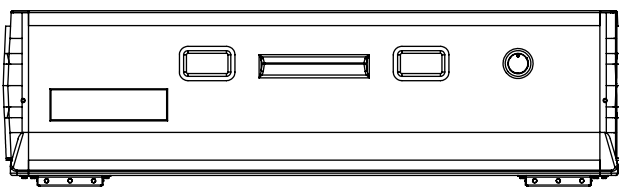
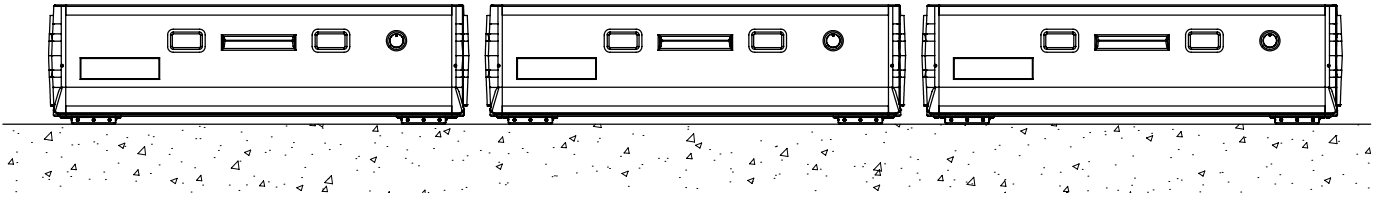

Crush hazard!

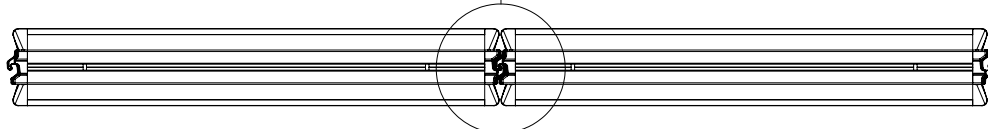
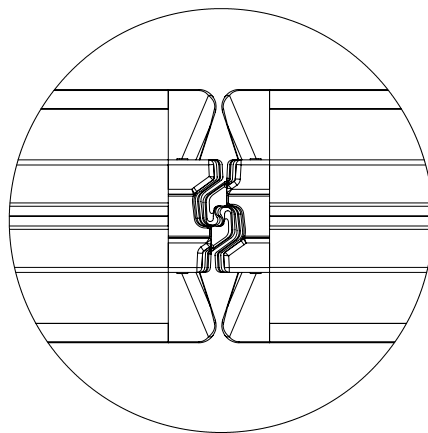
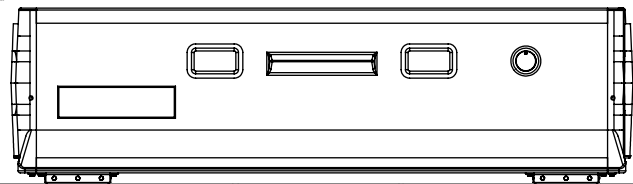

Safe lifting



- Only use lifting gear designed for the purpose.
- Take great care with respect to crush hazards.
- Check that the barriers are free, not frozen in place or obstructed. This is to avoid overloading the lifting gear.
- Never lift multiple interconnected barriers.
- Make sure that lifting tines and tine slots are free of snow and ice.
- Make sure that the necessary documentation for the chosen lifting gear is available and that instructions are properly followed.

Scissor-type lifting tool

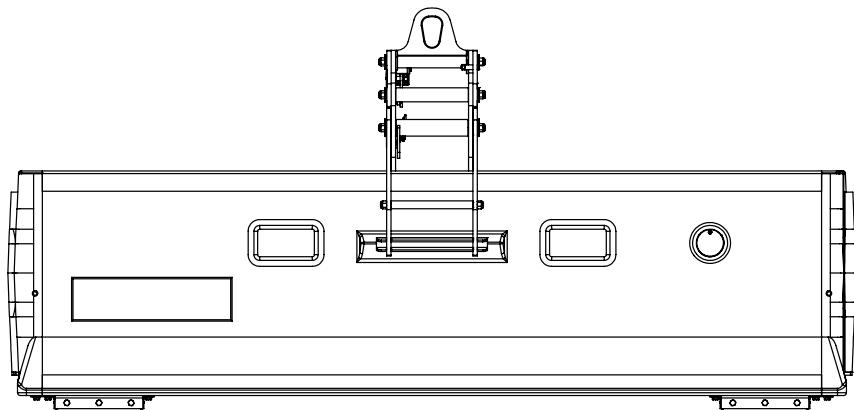
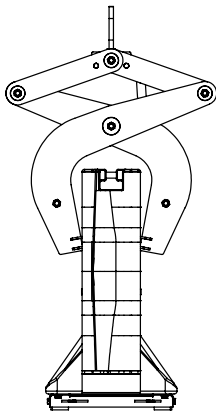

Forklift

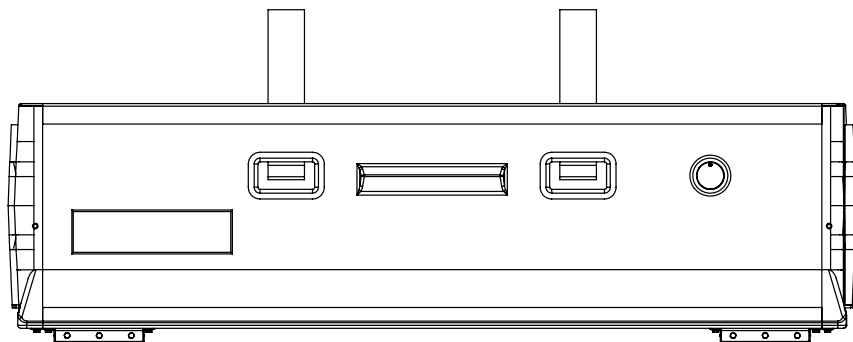
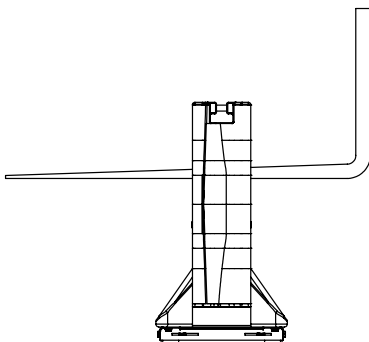

Installation radius

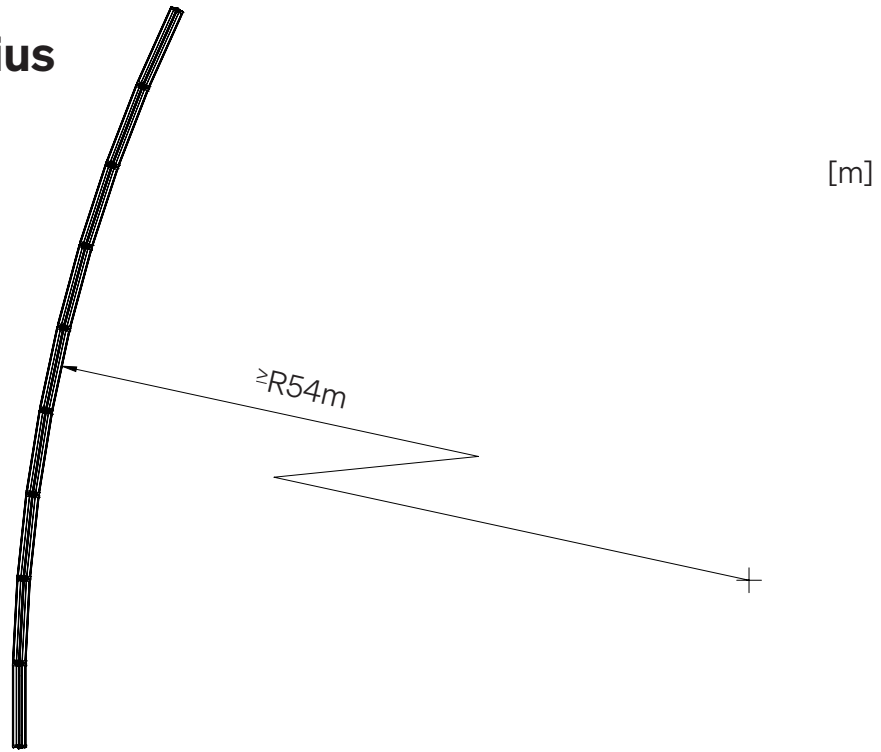

Vertical offset

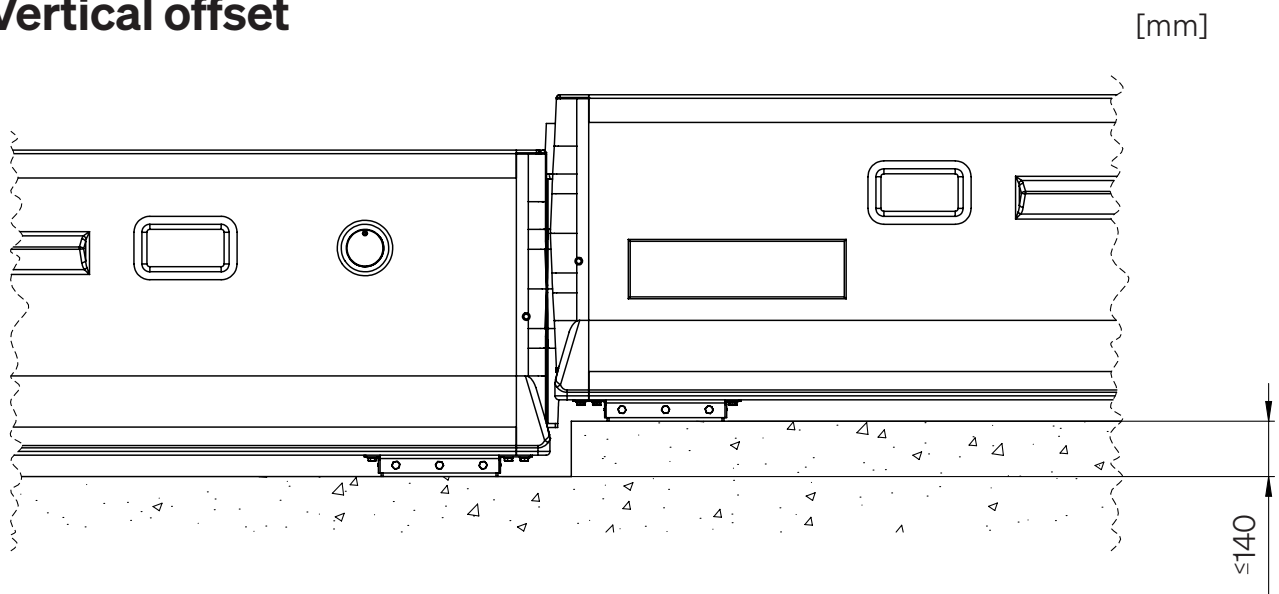

Angled – side

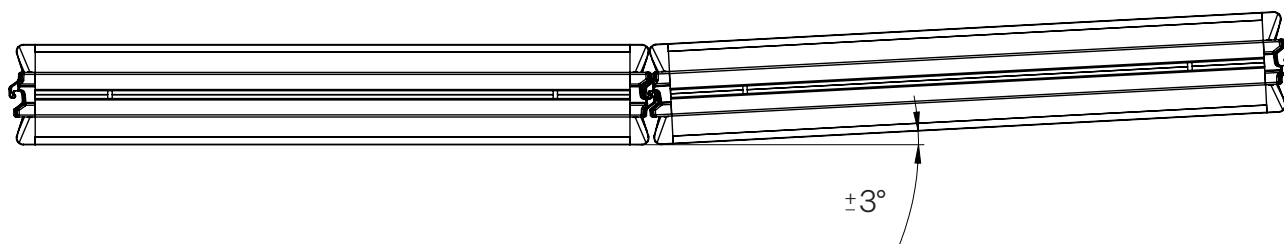

Angled – level

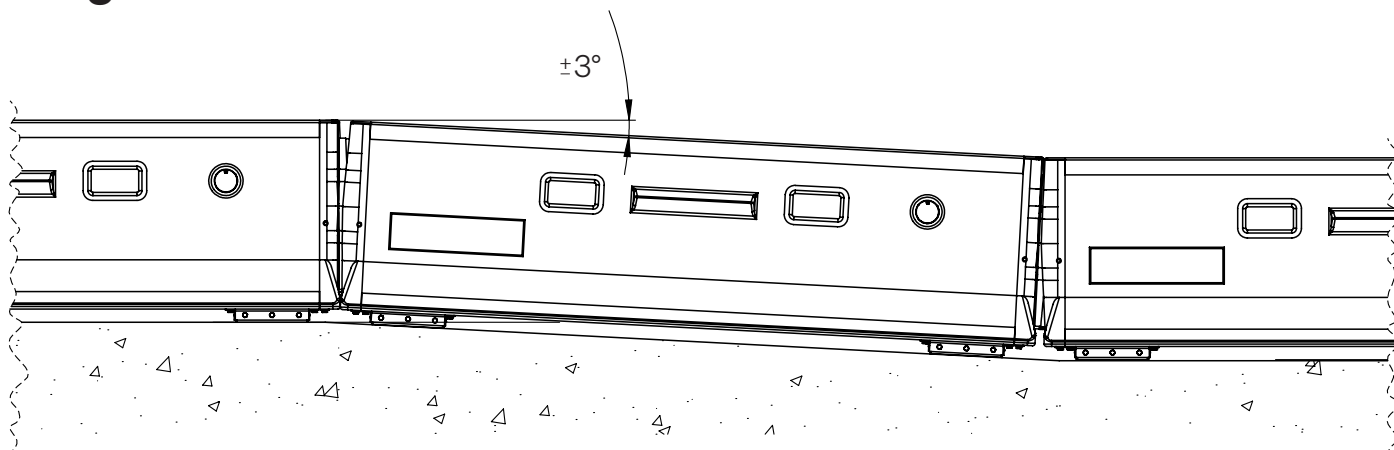

Barrier data

The performance figures relate to installation on an asphalt base in accordance with SS-EN 1317-2.

Capacity class in accordance with SS-EN 1317	T2
Barrier length	2.85 m
Working width class/Working width dimension	W2/0.8 m
Dynamic deflection	0.3 m
ASI (Acceleration Severity Index)	0.7
THIV (Theoretical Head Injury Velocity)	17 km/h
Injury risk class	A (lowest injury risk)
Minimum installation length	22.8 m (8 units)
Minimum erected length before/after work zone	8.55 m
Unit weight/erected weight	1,280/10,240 kg

Capacity class in accordance with SS-EN 1317	T3
Barrier length	2.85 m
Working width class/Working width dimension	W3/1.0 m
Dynamic deflection	0.5 m
ASI (Acceleration Severity Index)	0.4
THIV (Theoretical Head Injury Velocity)	11 km/h
Injury risk class	A (lowest injury risk)
Minimum installation length	28.5 m (10 units)
Minimum erected length before/after work zone	8.55 m
Unit weight/erected weight	1,280/12,800 kg

Barrier data

The performance figures relate to installation on an asphalt base in accordance with SS-EN 1317-2.

Capacity class N2 SVEA 2.85	N2
Barrier length	2.85 m
Working width class/Working width dimension	W5/1.7 m
Dynamic deflection	1.1 m
ASI (Acceleration Severity Index)	1.5
THIV (Theoretical Head Injury Velocity)	26 km/h
Injury risk class	C
Minimum installation length	34.2
Minimum erected length before/after work zone	11.4 m
Unit weight/erected weight	1,280/15,360 kg

Capacity class N2 SVEA 2.85 incl. SoundPanel and TopMesh	N2
Barrier length	2.85 m
Working width class/Working width dimension	W4/1.3 m
Dynamic deflection	0.9 m
ASI (Acceleration Severity Index)	1.5
THIV (Theoretical Head Injury Velocity)	26 km/h
Injury risk class	C
Minimum installation length	34.2
Minimum erected length before/after work zone	11.4 m
Unit weight/erected weight	1,280/15,360 kg

Safe storage management

When stacking barriers on top of each other, the following requirements must be met:

- To prevent compression of the rubber feet due to long-term high vertical loads, each layer must have timber litter or similar bedding.
- The number of barriers in a stack is limited to a maximum of 3.
- Make sure that the ground can take the weight and that the surface on which stacking takes place is as horizontal and level as possible.

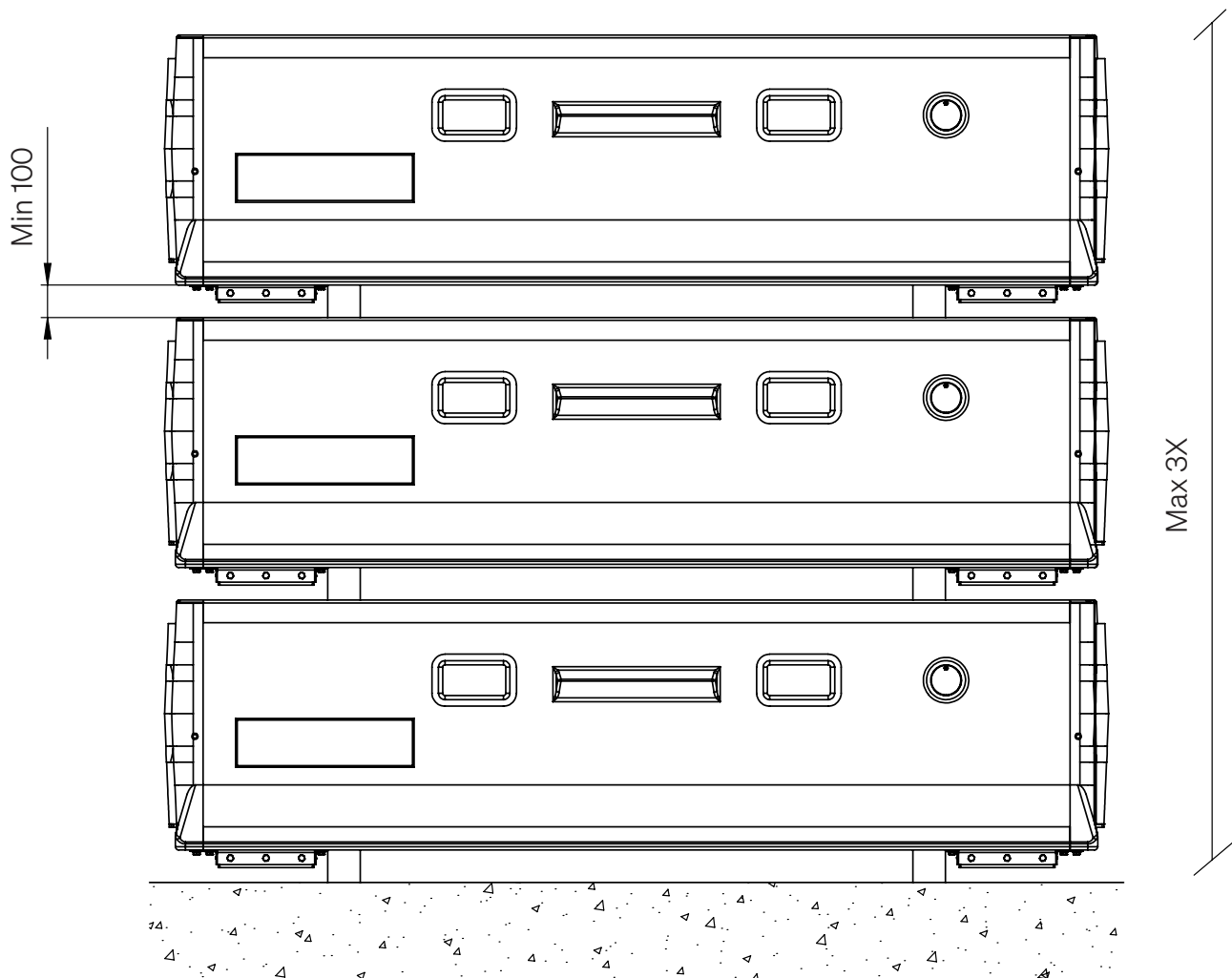

Checklist

Make sure that:

- Complete and up-to-date documentation is available
- The necessary personal protective equipment is used
- A risk assessment is completed before installation
- Only lifting gear designed for the purpose is used
- Only undamaged products are used
- The installation certificate is completed by an authorised installer and approved by the client (where the barriers are erected on a public highway)

Inspection

Before each occasion of use, a simple set of checks is recommended:

- Visual inspection of visible damage to the barrier's components, signs of collision or of a barrier being dropped during lifting or similar.
- Inspection of wear to the rubber feet. Make sure the feet are not worn down to the metal.

Each year, check the SVEA barriers for the following:

- Crack formation in or around welds.
- Rust around welds.
- Crack formation or deformations in lifting shafts and around lifting slots.
- Damage around the recess for a scissor-type lifting tool, concrete chipped off or similar.
- Wear on the rubber feet. On new feet, the thickness of the rubber to the metal frame is 9 mm all around. Replace the feet once worn down to 3 mm.

For assessment of damage and the relevant action:

Contact Ramudden Sourcing & Supply.

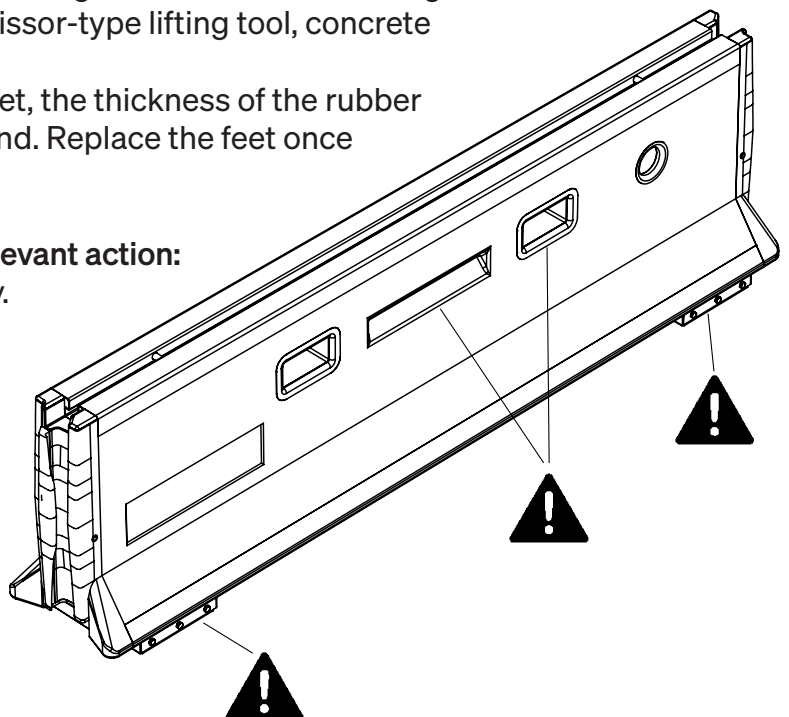

Accessories

The manufacturer is only liable for the product insofar as accessories designed for use with SVEA barrier systems are used and have been correctly installed in accordance with the installation instructions supplied with them.

A list of accessories is provided below. Each accessory or accessory system has separate installation instructions associated with the relevant article number.

SVEA Start/Stop

Art. No. 949103

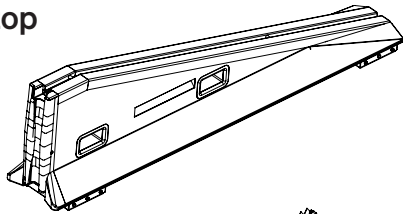

SVEA 90 degree angle

Art. No. 949104

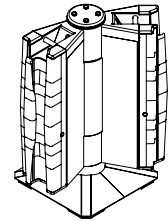

SVEA SoundPanel

Art. No. 949105

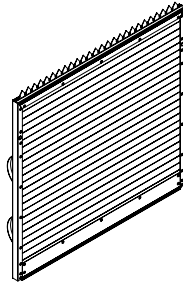

SVEA Pillar for SoundPanel

Art. No. 949115

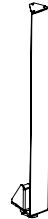

SVEA TopMesh

Art. No. 949113

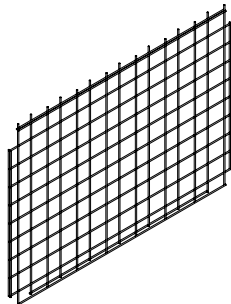

SVEA Pillar for TopMesh

Art. No. 949112



SVEA Panel lock

Art. No. 949110

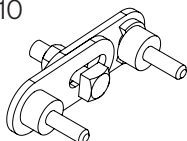

SVEA Barbed wire

Art. No. 949112



SVEA Pillar for barbed wire

Art. No. 949114

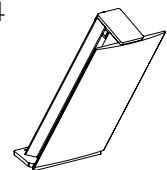

Ärendenummer
TRV TRV 2021/52389
Ert ärendenummer
[Motpartens ärendelD NY]
Sidor
1(2)

BESLUT

Beslutat av
Petra Fluor
Dokumentdatum
2021-04-26



WORXSAFE AB
Patrick Holmbom
Nifsåsvägen 9
SE-83152 Östersund
Sweden

Beslut om tillåtelse av WORXSAFE WXS 2.85 kapacitetsklass T2 och T3.

Beslut

Trafikverket beslutar, med utgångspunkt från resultat från nedanstående rapporter, beskrivningar samt VTI:s utlåtande, att WORXSAFE WXS 2.85 kapacitetsklass T2 och T3 accepteras som temporärt skydd för bruk på allmänna vägar där staten är väghållare, i kapacitetsklass T2 skaderisk klass A, arbetsbredd w2 och T3 skaderisk klass A, arbetsbredd W3 enligt EN 1317-2. Beslutet gäller under förutsättning att villkoren nedan följs.

Bakgrund

Worxsafe AB har ansökt om att få WORXSAFE WXS 2.85 kapacitetsklass T2 och T3 tillåten som temporär skyddsanordning på allmänna vägar där staten är väghållare.

Till ansökan, som inkom den 2021-04-15 bifogades dokumentation i form av ett USB-minne innehållande:

- 3 test protokoll utförda i TB21, TB 22 och TB41 som är utförda på Transpolis, Frankrike.
- USB minnen med korresponderande video från testerna.
- Installationsmanual, ritningar och med kompletterande produktinformation.

Villkor

- WORXSAFE WXS 2.85 kapacitetsklass T2 ska ha en installerad barriärslängd på minst 22,8 meter/8 stycken oförankrade 2,85 meters block, och sträcka sig minst 8,55 meter förbi den arbetsplats barriären avser att skydda, åt båda hållen.
- WORXSAFE WXS 2.85 kapacitetsklass T3 ska ha en installerad barriärslängd på minst 28,5 meter/10 stycken oförankrade 2,85 meters block, och sträcka sig minst 8,55 meter förbi den arbetsplats barriären avser att skydda, åt båda hållen.
- WORXSAFE WXS 2.85 kapacitetsklass T2 och T3 ska vara sammankopplat i hela sin längd.
- Slitaget på gummifötterna ska kontrolleras innan montage av WORXSAFE WXS 2.85 kapacitetsklass T2 och T3.
- Underlaget ska motsvara testernas förhållanden.

Till produkten ska det medfölja monterings och bruksanvisningar på svenska där leverantören tydligt visar de krav som ställs på en godkänd montering t.ex. underlag och översyn av gummifötterna.

Ärendenummer
TRV TRV 2021/52389
Ert ärendenummer
[Motpartens ärendeID NY]
Sidor
2(2)

BESLUT

Beslutat av
Petra Fluor
Dokumentdatum
2021-04-26



Föredragande, samråd och sakgranskning

Trafikverket har anlitat Jan Wenäll, VTI, för granskning av dokumentationen från den utförda testen. VTI har lämnat yttrande och kommenterat WORXSAFE WXS 2.85 i kapacitetsklass T2 och T3 vilket ligger som grund till detta beslut.

Beslut i detta ärende har fattats av enhetschef Petra Fluor. Föredragande har varit utredaren Jan Backman.

Övriga upplysningar

Beslutet gäller tillsvidare. Trafikverket kan dock upphäva beslutet med omedelbar verkan om erfarenheter av användningen visar att produkten inte fungerar på ett trafiksäkert sätt och avsett vis.

Petra Fluor

Enhetschef avdelning Nationell åtgärdsplanering

Nationell planering

WORXSAFE

Declaration of Performance – N° 1137-CPR-0610/69-1



Manufacturer	Worxsafe AB Nifsåsvägen 9 831 52 Östersund Sweden	
Declares that the following product	WXS 2.85 Identification Code: 300002	
Complies with the following harmonized standards	EN 1317-1/2:2010 & EN 1317-5:2007+A22012/AC:2012	
Notified Body	asbl COPRO vzw Z.1 Researchpark - Kranenberg 190 - BE-1731 Zellik (Asse) BE 0424.377.275 - RPM Bruxelles/RPR Brussel Notified Body n° 1137	
System of Assessment and Verification of Constancy of Performance	System 1	
Declared Performance	Containment Level	N2
	Impact Severity Level	C
	Normalized Dynamic Deflection	1.1 m
	Normalized Working Width	1.5 m - W5
Durability	Galvanized according to ISO 1461	
Intended Use	The WXS 2.85 is a concrete safety barrier intended for use on roads and around worksites.	

Pär Johansson
CEO
Worxsafe AB
Östersund, Sweden

WORXSAFE

Declaration of Performance – N°1137-CPR-0610/69-2

CE 1137

Manufacturer	Worxsafe AB Nifsåsvägen 9 831 52 Östersund Sweden
Declares that the following product	WXS 2.85 with SVEA SoundPanel Identification Code: 300002
Complies with the following harmonized standards	EN 1317-1/2:2010 & EN 1317-5:2007+A22012/AC:2012
Notified Body	asbl COPRO vzw Z.1 Researchpark - Kranenberg 190 - BE-1731 Zellik (Asse) BE 0424.377.275 - RPM Bruxelles/RPR Brussel Notified Body n° 1137
System of Assessment and Verification of Constancy of Performance	System 1
Declared Performance	Containment Level N2 Impact Severity Level C Normalized Dynamic Deflection 0.9 m Normalized Working Width 1.3 m - W4
Durability	Galvanized according to ISO 1461
Intended Use	The WXS 2.85 with SVEA SoundPanel is a concrete safety barrier with parapets intended for use on roads and around worksites.

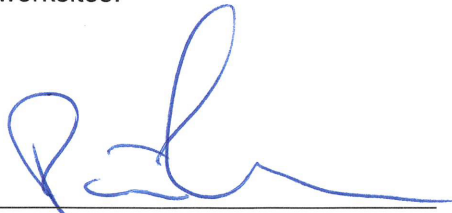

Pär Johansson
CEO
Worxsafe AB
Östersund, Sweden



















Things to bear in mind:

IN GENERAL

- Always read the manufacturer's instructions carefully to ensure the product is used in a correct and safe manner.
- If anything is unclear, contact the manufacturer or the relevant sales point.
- Never mix products of different brands.
- Always observe the specified load restrictions.

STORAGE

- Wherever possible, store the products in a non-corrosive environment.
- Remember to store the products in the way intended by the manufacturer: e.g. in the case of stacking, to minimise the risk of damage/injury from tipping over or similar.

 Technical information	 Weight	 Nm Torque-tighten bolted joints
 Inspect	 Recycling	 Undo bolted joints
 Inspection interval in days	 Correct	 Max. permitted wind speed
 Inspection interval in months	 Incorrect	 Force
 Check straightness	 Attention!	 Torque
 Check crack formation	 Tighten bolted joints	 "Thread in"