

SVEA SMA Kopplingskit

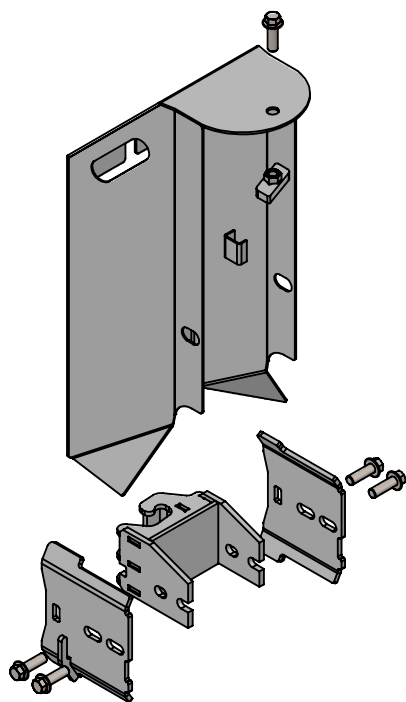

Varmförzinkad



Stål



23

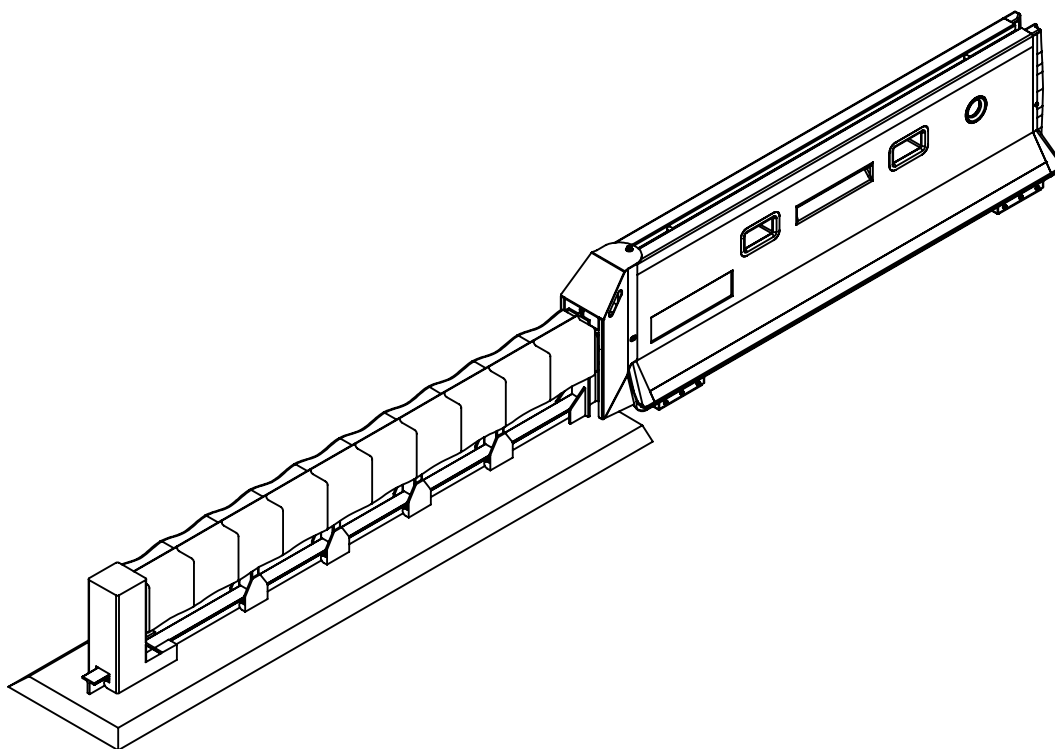

Ingående delar

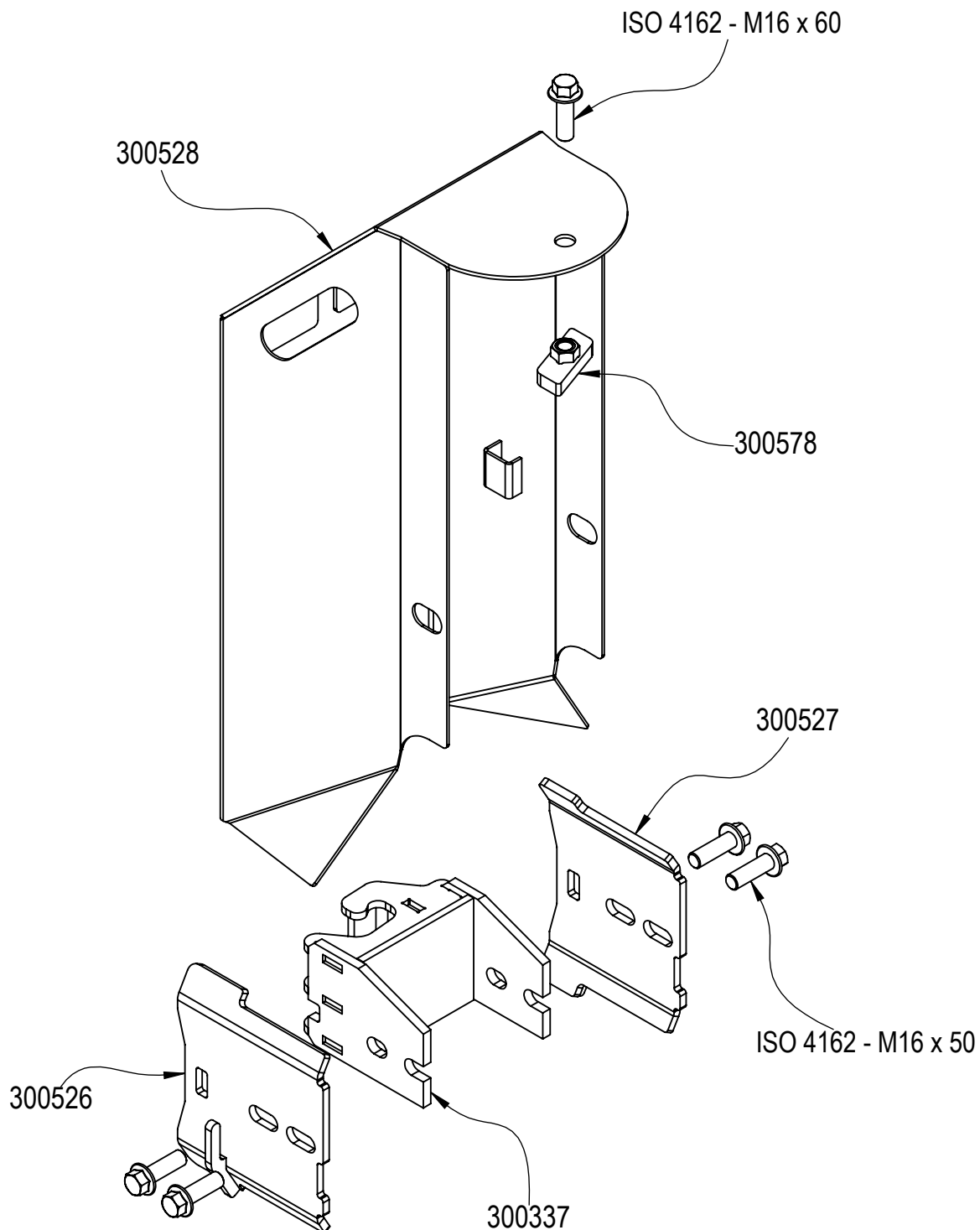

Montage

1.

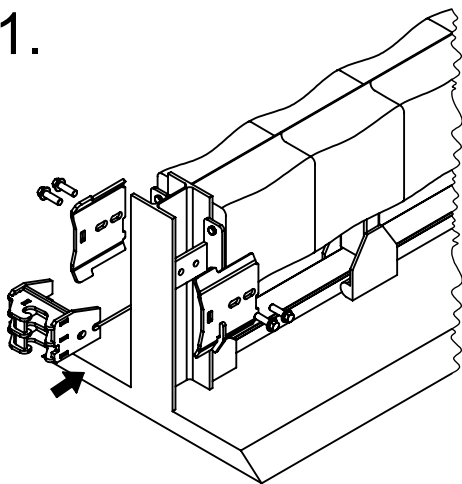

2.

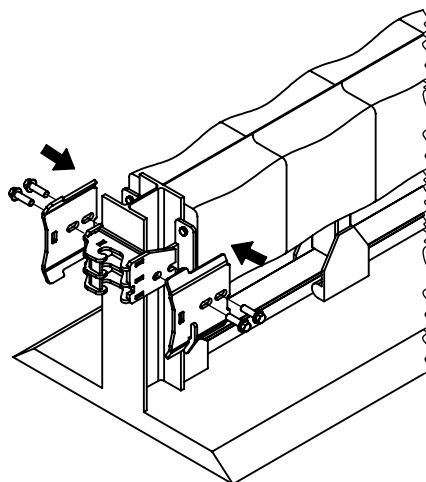

3.

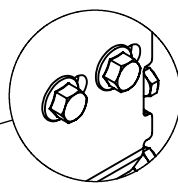
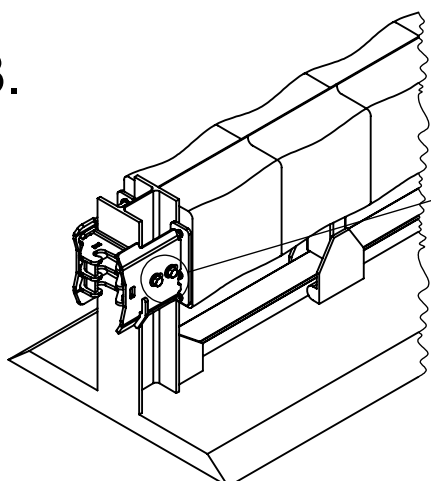

21 mm

Undvik att dra skruvarna hårt. Adapterplåten ska fortfarande kunna glida i sidled. Slutgiltig dragning sker i ett senare steg.

4.

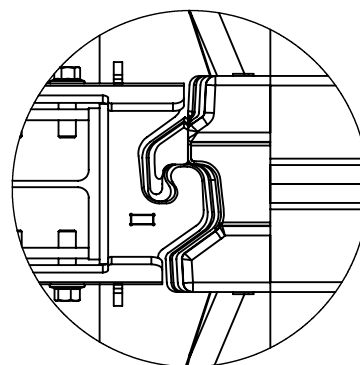
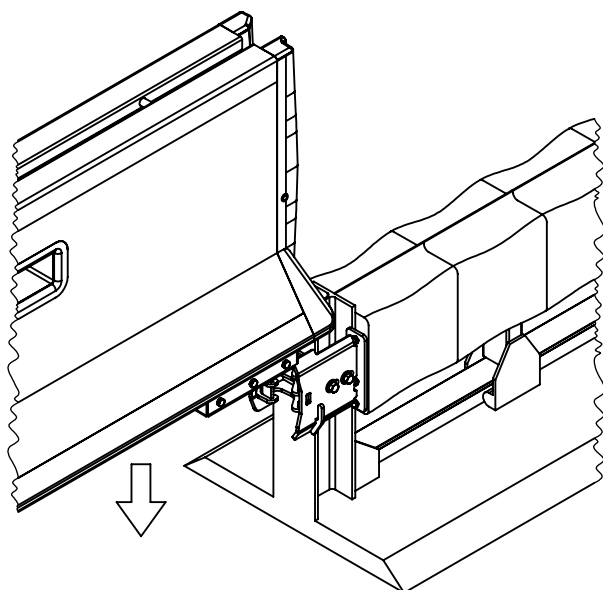

Montage

5.

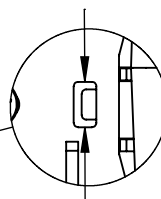
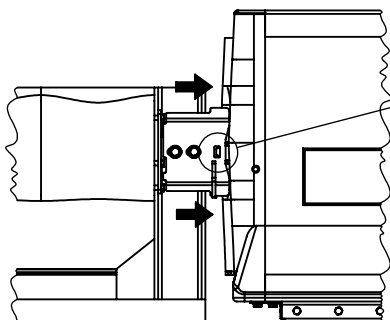

Spänn adapterplåten mot barriärens koppling genom att bända med en skruvmejsel i det markerade urtaget. Fäst skruvarna hårt när adapterplåten är spänd. Upprepa på den andra sidan.

6.

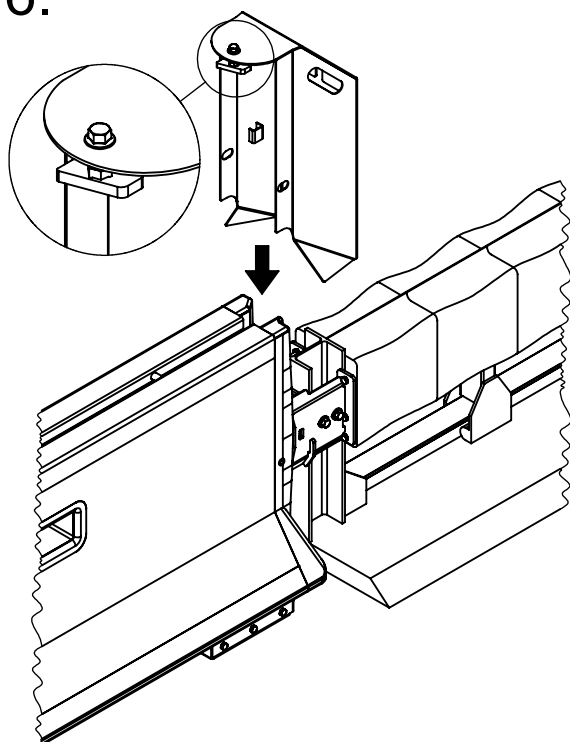

7.

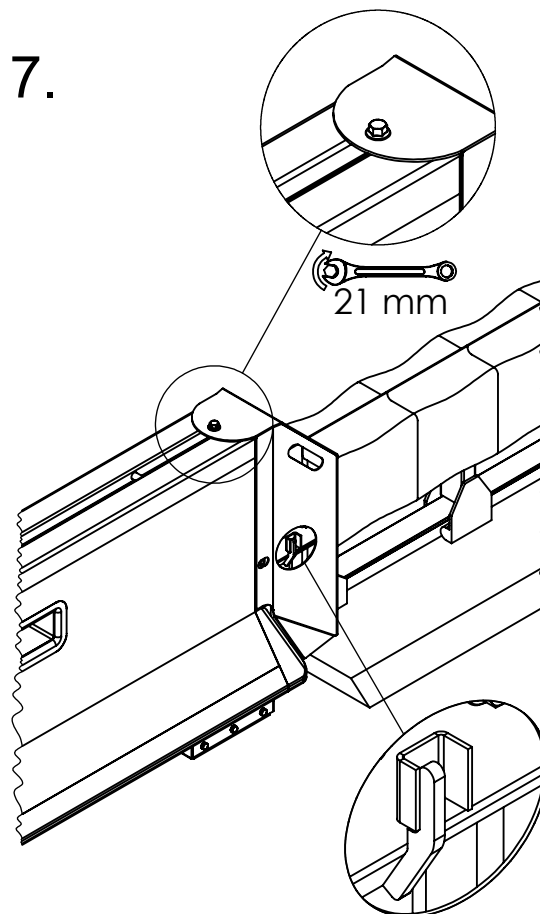

Säkerställ att kåpan hakar fast i adapterplåtens krokar på båda sidor.

Montage - X3 Markerings-skärm (Valfritt)

8.

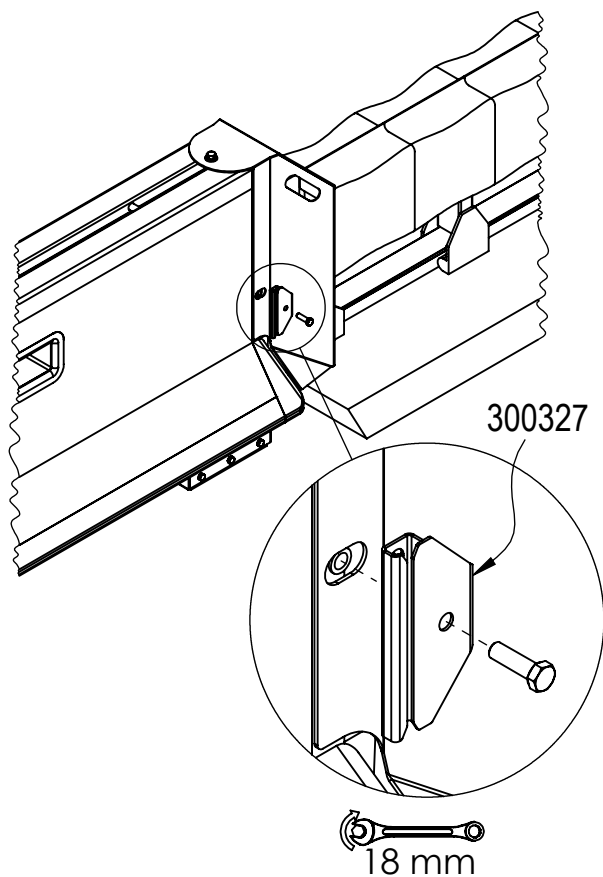

9.

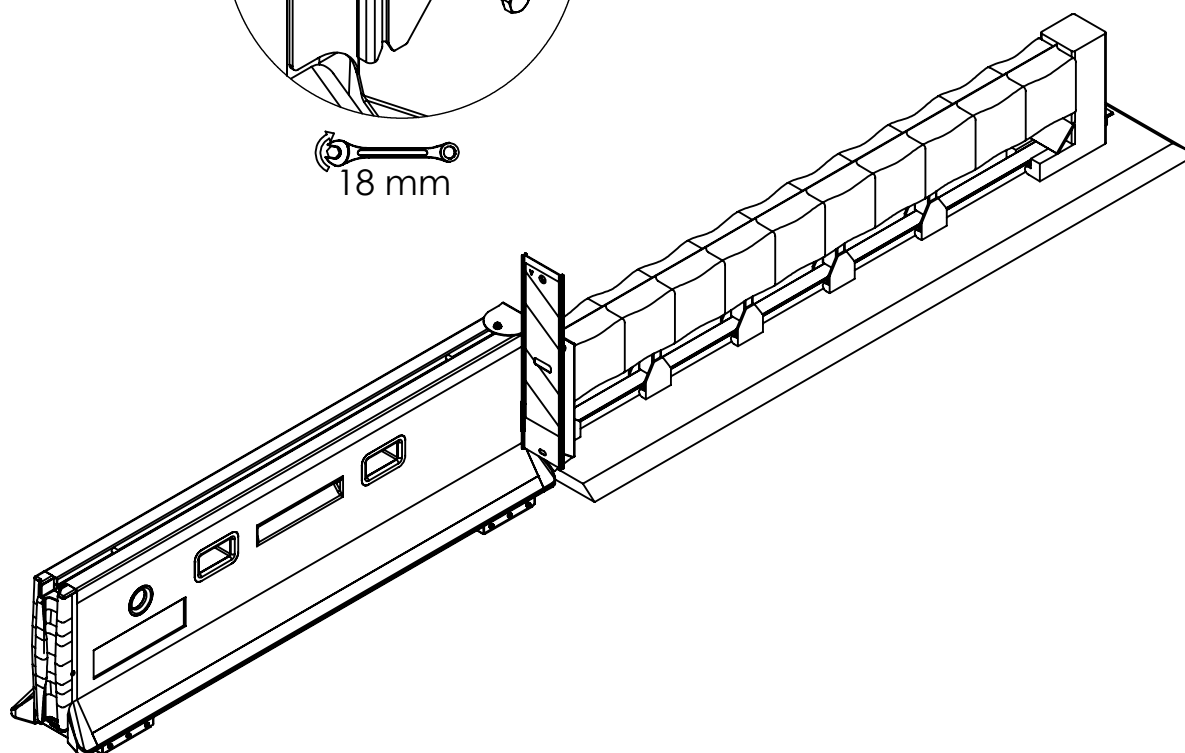
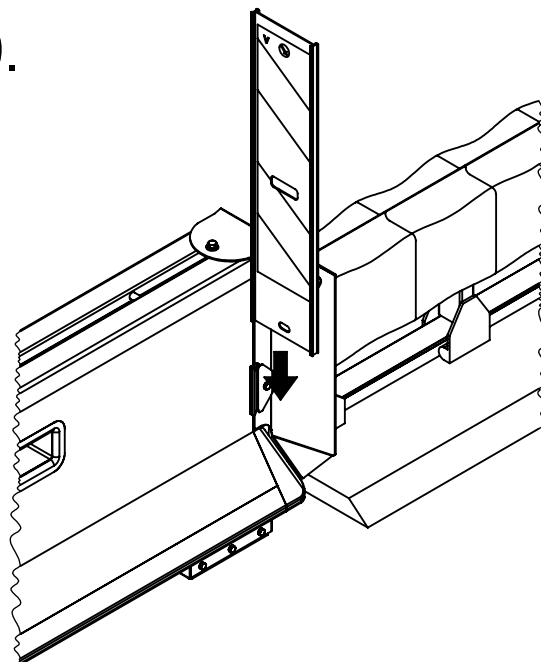















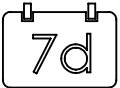

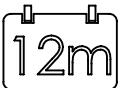
GENERELLT

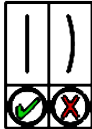
- Läs alltid igenom tillverkarens anvisningar för att säkerställa att produkten används på ett korrekt och säkert sätt.
- Vid oklarheter, kontakta tillverkaren eller aktuellt säljställe.
- Blanda aldrig produkter av olika fabrikat med varandra.
- Respektera alltid specificerade belastningsbegränsningar.

FÖRVARING

- Förvara i möjligaste mån produkterna i icke-korrosiv miljö.
- Tänk på att förvara produkterna på enligt tillverkaren avsett vis exempelvis vid stapling för att minimera risken för skador i samband med vältnig eller liknande.

 Teknisk information	 Vikt	 Nm Momentdra skruvförband
 Inspektera	 Återvinning	 Lossa skruvförband
 Inspektionsintervall i dagar	 Korrekt	 Max tillåten vindhastighet
 Inspektionsintervall i månader	 Inkorrekt	 Kraft
 Kontrollera rakhet	 Se upp!	 Moment
 Kontrollera sprickbildning	 Drag åt skruvförband	 "Trä i"