

GC-Räcke Klass 1, 2 & 3

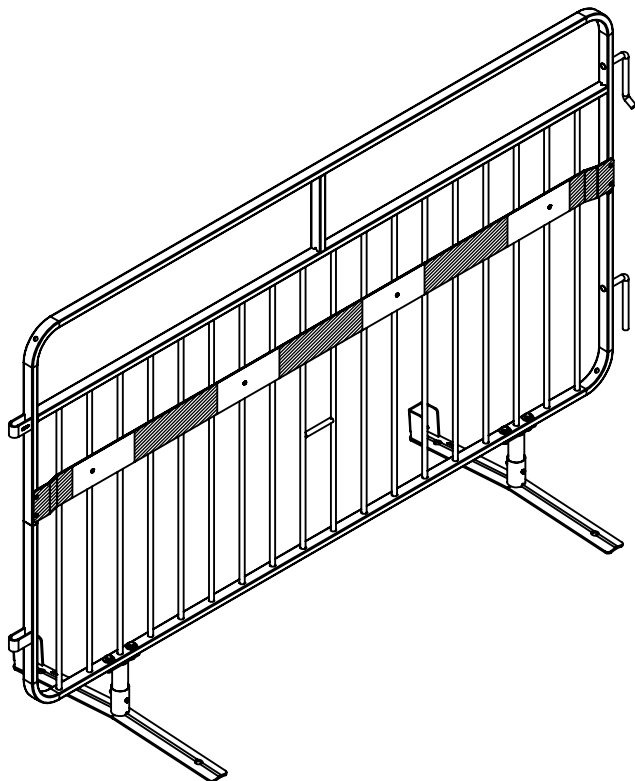

Varmförzinkad



Stål



25

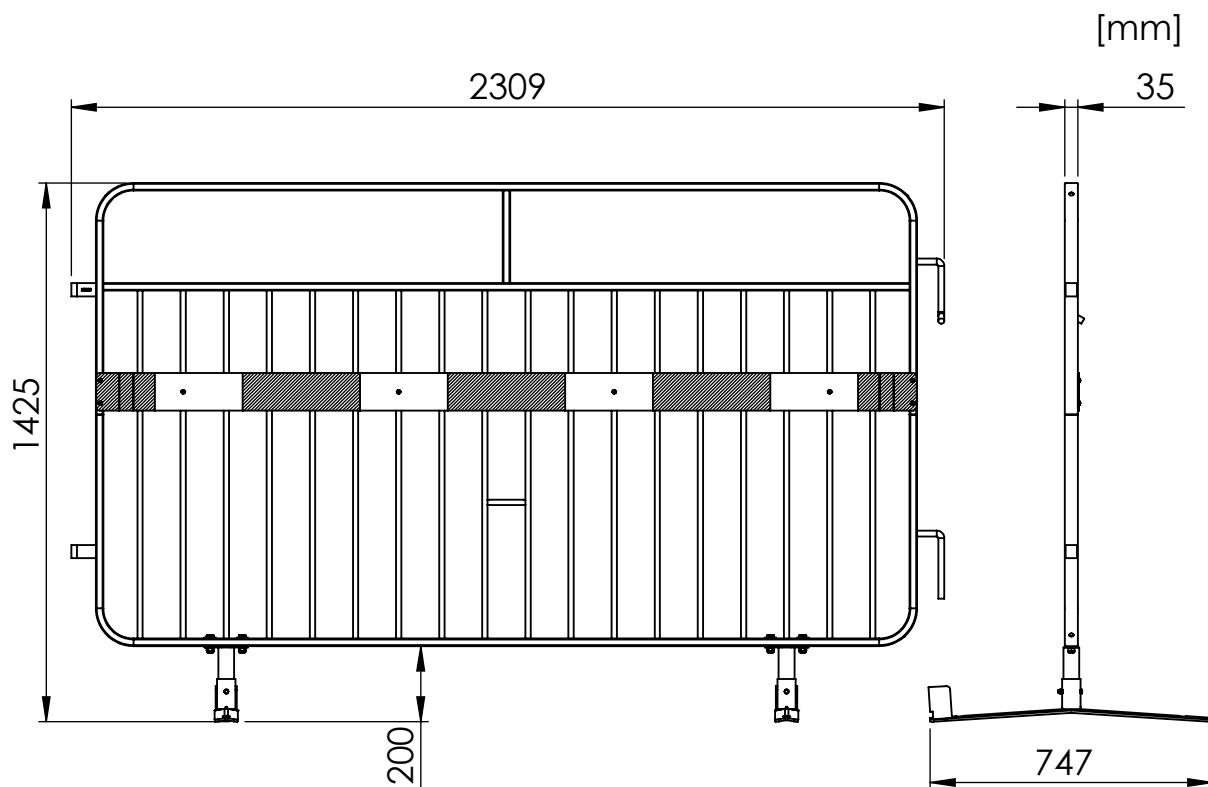

Montage

1.

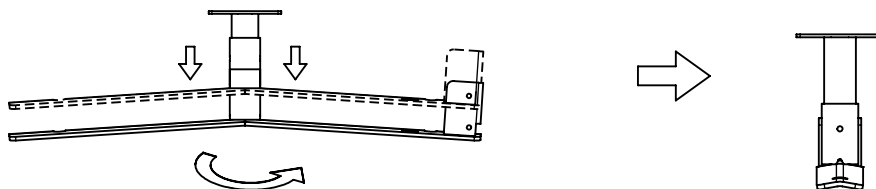

2.

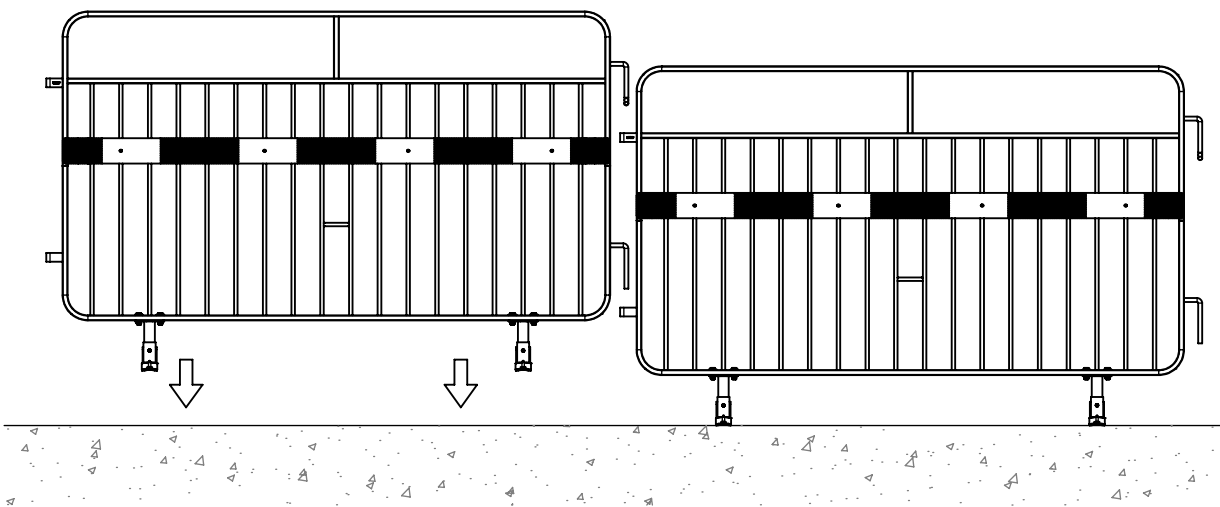

Vindlast



För att klara vindlaster högre än 14 m/s måste raka uppställningar förankras/viktas

Max 14 m/s

> 20 m/s

> 20 m/s

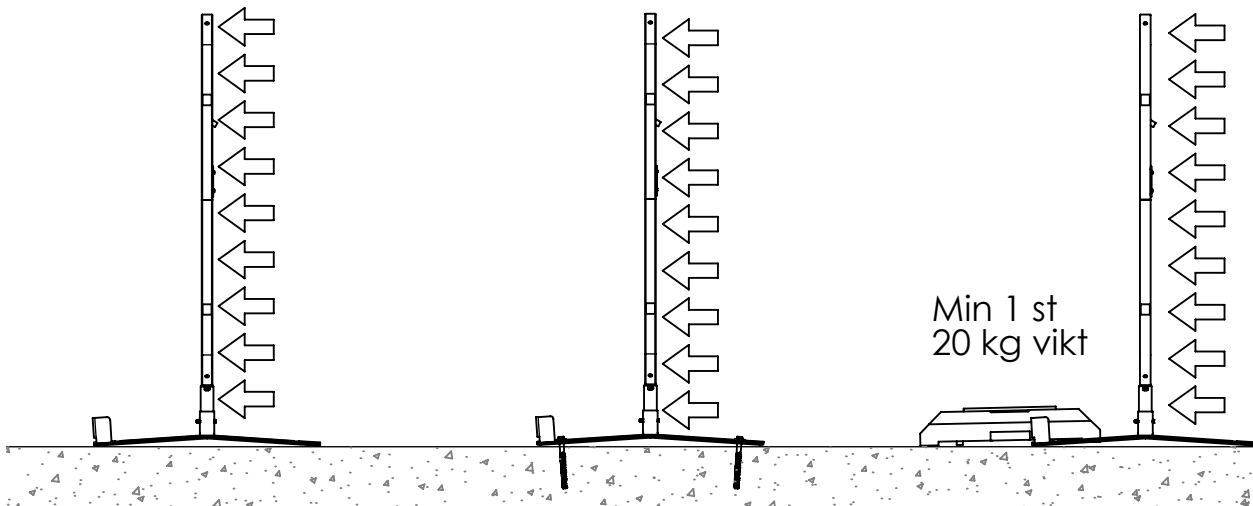

Godkända uppställningar SS 7750-1

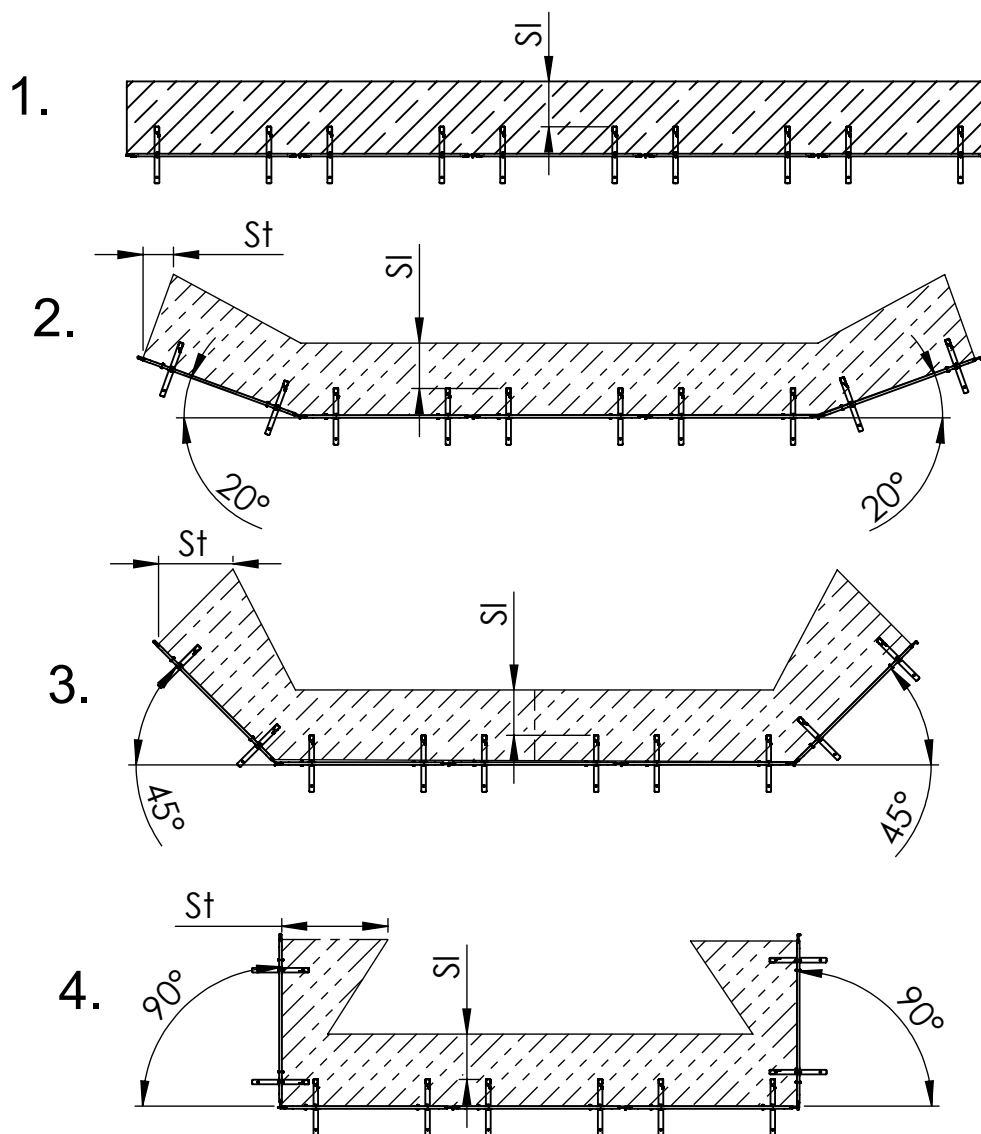

För ett godkänt montage krävs 1st 20 kg vikt per grind.

Provad konfiguration	Minsta Längd längsgående [m]	Minsta Längd tvärgående [m]	Rörelsebredd tvärgående [m] St			Rörelsebredd längsgående [m] SI		
			Klass 1	Klass 2	Klass 3	Klass 1	Klass 2	Klass 3
1. Rak	11,4	-	-	-	-	0,4	0,8	1,1
2. Vinklad 20°	11,1	0,8	0,4	0,6	1,7	0,4	0,8	1,1
3. Vinklad 45°	10,1	1,6	0,7	1	2,4	0,4	0,8	1,1
4. Vinklad 90°	6,9	2,3	0,9	1,1	2,5	0,4	0,8	1,1

Alla provade konfigurationer motsvarar 5st sektioner

Transport/Packning

8343082

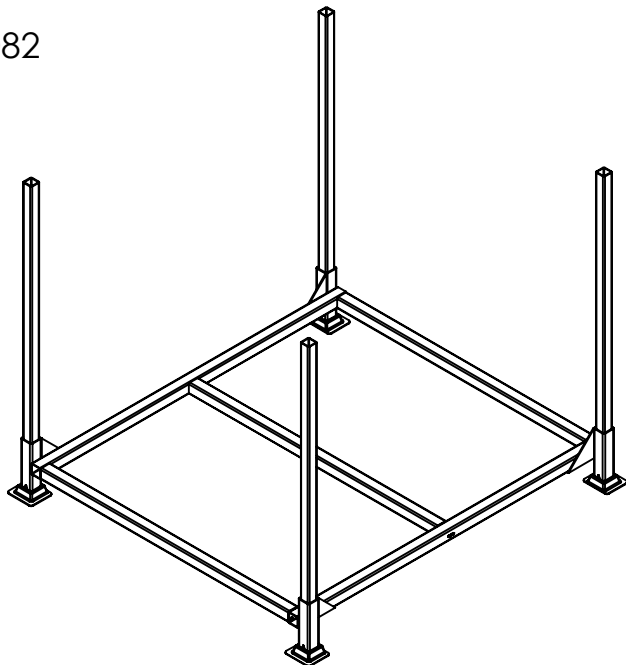

Varmförzinkad



Stål



48

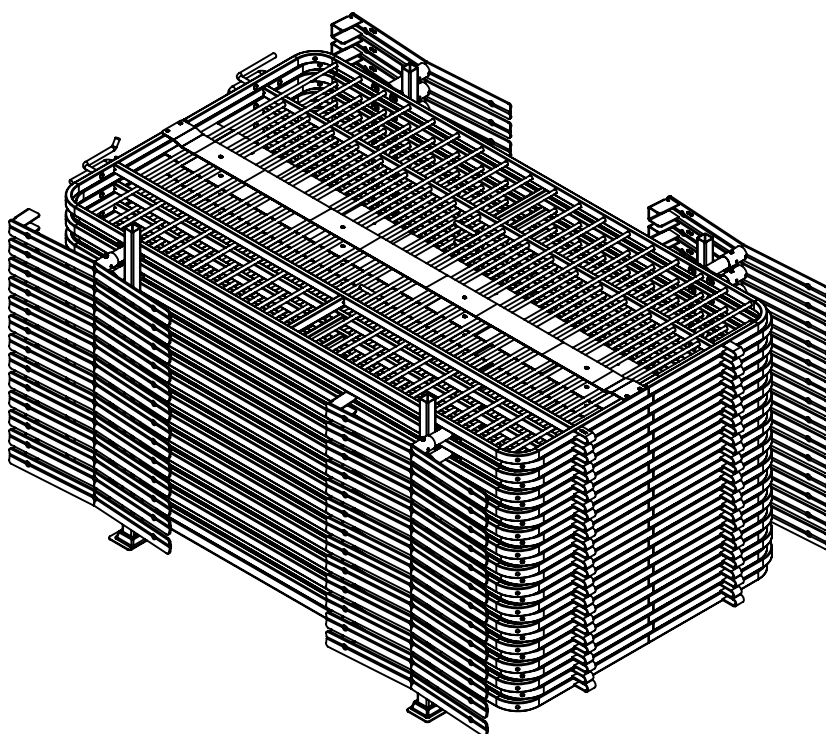

Max 28 st



720



Reservdelar

8342784 - Fot

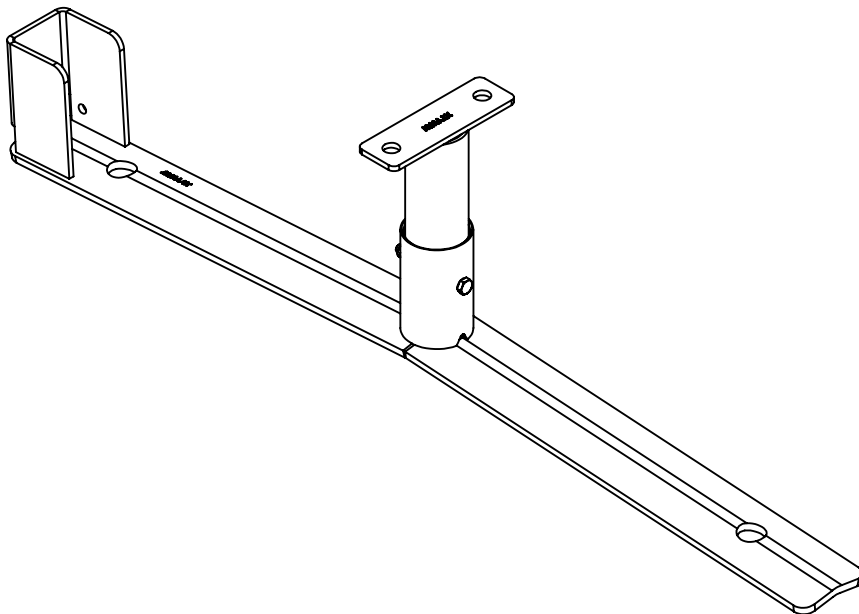

8344727 - Reflex

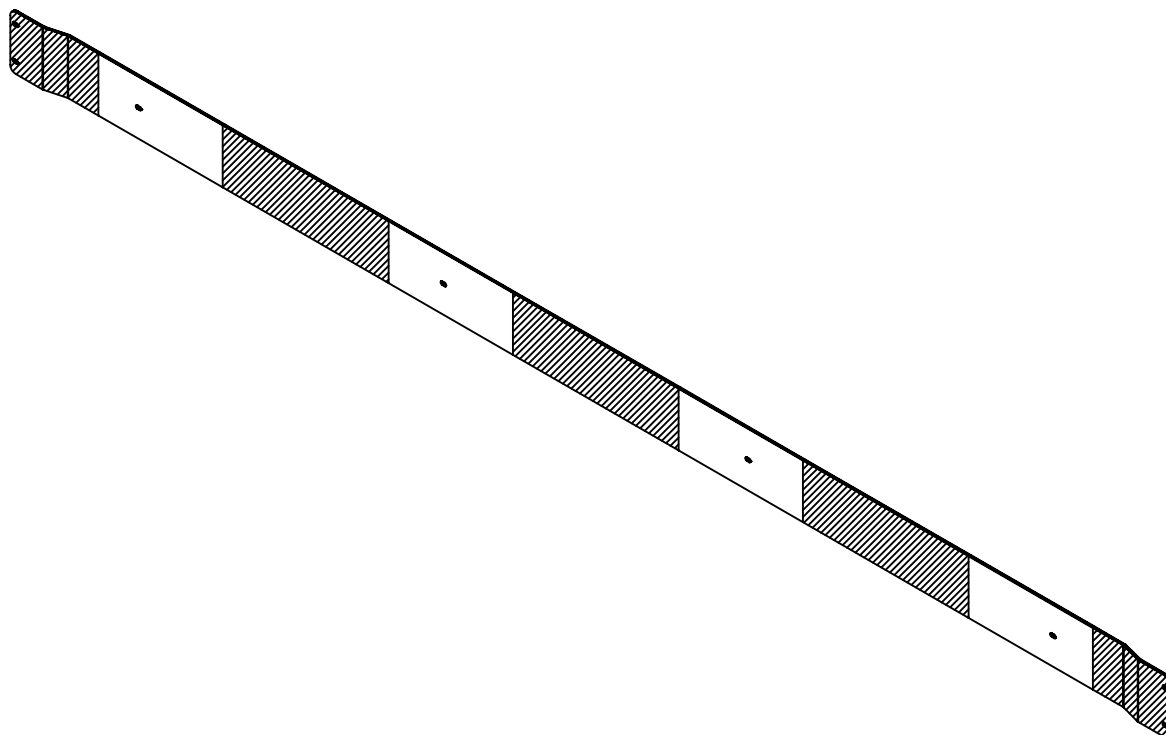















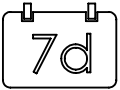

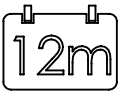
GENERELLT

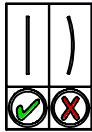
- Läs alltid igenom tillverkarens anvisningar för att säkerställa att produkten används på ett korrekt och säkert sätt.
- Vid oklarheter, kontakta tillverkaren eller aktuellt säljställe.
- Blanda aldrig produkter av olika fabrikat med varandra.
- Respektera alltid specificerade belastningsbegränsningar.

FÖRVARING

- Förvara i möjligaste mån produkterna i icke-korrosiv miljö.
- Tänk på att förvara produkterna på enligt tillverkaren avsett vis exempelvis vid stapling för att minimera risken för skador i samband med vältnig eller liknande.

 Teknisk information	 Vikt	 Nm Momentdra skruvförband
 Inspektera	 Återvinning	 Lossa skruvförband
 Inspektionsintervall i dagar	 Korrekt	 Max tillåten vindhastighet
 Inspektionsintervall i månader	 Inkorrekt	 Kraft
 Kontrollera rakhet	 Se upp!	 Moment
 Kontrollera sprickbildning	 Drag åt skruvförband	 "Trä i"